

---

## Forming Reasonable Expectations of Modern Tri-Band Beam Designs

L. B. Cebik, W4RNL (SK)

---

The most modern tri-band beams for 20, 15, and 10 meters have given up traps in favor of using individual elements for each band. Optibeam, Force 12, and Bencher all have beams based on this premise. Even for relatively close total boom lengths, the element positions vary considerably. The feed systems use either open-sleeve coupling or direct-drive systems—or a combination of both. Compared to older trap and hybrid designs, the newer beams present a somewhat bewildering appearance, as if the boom were a porcupine on a bad-hair day.

The somewhat confusing appearance presents many would-be users with more than one quandary. Perhaps the most central is this question: what should I reasonably expect by way of performance from these beams? We are not wholly at the mercy of the manufacturer's specification sheets in forming our expectations. Instead, if we can understand what goes into the design of such beams and can develop an understanding of the performance of appropriately comparable monoband beams, we can develop expectations that fit virtually any of the newer designs. The goal of this set of notes is to go some distance in this direction.

My purpose is not to review or evaluate any particular commercial design. Therefore, we shall not use any of the commercial offerings as the foundation for our study. Instead, I developed a special design that will help me illustrate a number of points along the way. **Fig. 1** shows the outline of the NEC-4 design model. The sketch identifies the ostensible function of each element and shows the segmentation of the model. It uses 10 elements on an 18' boom. The reason for restricting the boom length will become apparent when we examine the array, band by band. Also listed are the element diameter stepping schedules, which coincide with the medium-duty elements shown in the excellent collection of monoband HF beams in *The ARRL Antenna Book*; see Chapter 11 of any recent edition. **Table 1** lists the details of the structure.

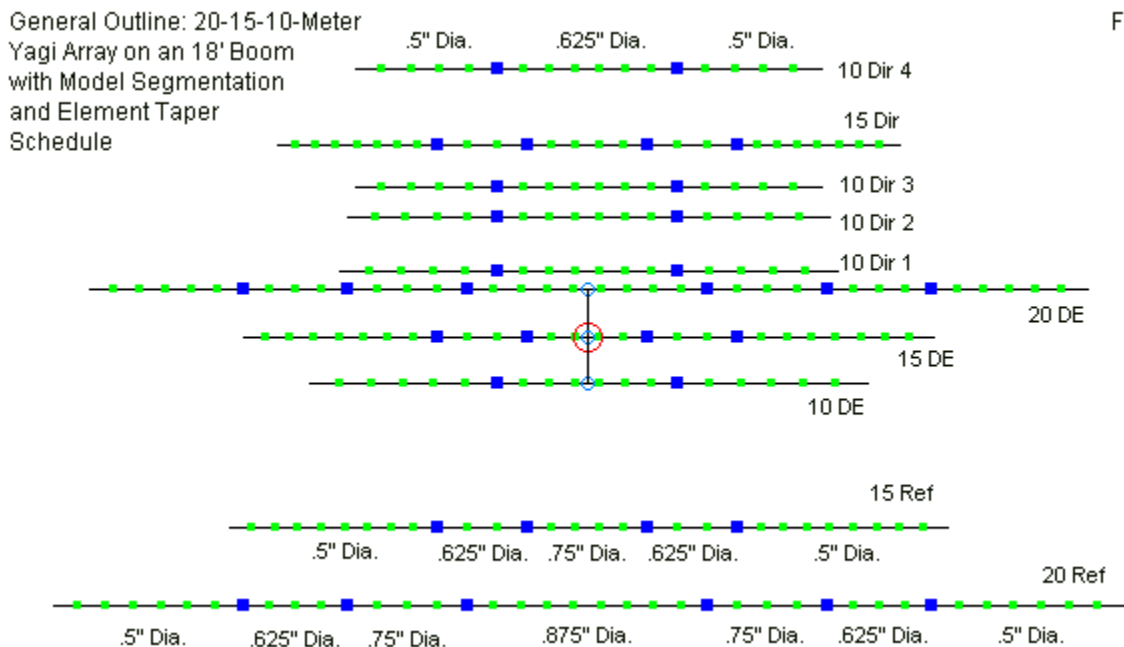

Table 1. Specimen 10-Element Tri-Band Array: 15-meter feedpoint, 70-Ω line: dimensions

20-meter Yagi			15-meter Yagi			10-Meter Yagi		
Element	Dia.	Length	Element	Dia.	Length	Element	Dia.	Length
Both	0.875"	48"	All	0.75"	24"	All	0.625	36"
	0.75	96		0.625	60	DE tip	0.5	112
	0.625	138	Ref tip	0.5	144	Dir 1 tip	0.5	100
Ref tip	0.5	215	DE tip	0.5	139	Dir 2 tip	0.5	97
DE tip	0.5	200	Dir tip	0.5	125	Dir 3 tip	0.5	94
						Dir 4 tip	0.5	94

Array	Spacing	Notes:
20-m ref	0"	1. Length values progressive from element center.
15-m ref	31.5	2. Reference dimensions to Fig.1.
10-m DE	89	3. Spacing values reference to parallel elements.
15-m DE	107.5	4. 15-m-to-20-m TL = 70 Ω normal.
20-m DE	127	5. 20-m-to-10-m TL = 70 Ω normal.
10-m Dir 1	134	6. Feedpoint: 15-meter DE
10-m Dir 2	156	7. Boom length: 17.92' plus ends.
10-m Dir 3	168	
15-m Dir	184.5	
10-m Dir 4	215	

The feed system notations refer to the direct-drive system. The system shown here is adapted from the one employed by Optibeam on some of its arrays. As **Fig. 1** shows, the drivers are arranged in band order with the 10-meter driver to the rear. Instead of using the 20-meter driver as the point of connection for the main 50-Ω feedline, the 15-meter driver in the center of the cluster is the connection point. From this driver forward to the 20-meter driver and rearward to the 10-meter driver, we have short 50-70-Ω feedlines. Such lines require square or other flat-face stick, since we cannot go below about 80 Ω with round wires. On any given operating frequency, the main feedline sees the parallel combination of the active driver impedance plus the off-band impedances of the other drivers. Of course, the 10-meter and 20-meter impedances are transformed a small amount by the connecting transmission line to the main feedline connection point. Alternative systems might use the 20-meter driver as the main connection point and place a higher-band driver on each side. A direct-drive system tends to offer broader SWR bandwidths on the higher bands in the array than open-sleeve coupling. Some arrays use a hybrid system. The feed system does have some consequences that we may examine as we study the array on each band.

I did not design this beam with the prospect that someone might build it. As we shall discover, the gain is far from balanced as we move from band to band. In addition, no commercial design would use as many 10-meter directors with such a short boom. It is possible to build this beam and obtain the listed performance values—after careful construction and field adjustment, of course. However, the beam design emerged to fulfill a number of goals for this exercise.

1. The beam design should illustrate some of the expectations that might arise for arrays using few to many elements.
2. The beam should demonstrate a significant number of the principles that go into what I have termed modern designs.

3. The design should achieve maximum the operating bandwidth, with relatively smooth gain and front-to-back ratio curves and with 50-Ω SWR values no higher than 1.5:1 across the lower two bands and from 28.0 to 29.0 MHz.

In a general way, the design uses 2 elements on 20, 3 elements on 15, and 5 elements on 10 meters to achieve all of its design goals. As one might expect, the forward gain increases as we move upward through the bands. One question that often accompanies an examination of such beams is whether the gain per band is a reasonable figure to expect. To help us answer that question, we shall also employ some reference monoband beam designs taken from my collection of models.

Should you contract an urge to build this design and find no cure, remember that NEC-4 models presume that all elements are well insulated and isolated from a conductive support boom. NEC has no way to model the transverse currents around the boom that modify the current distribution on directly connected elements.

Let's look at the array band by band, beginning with 20 meters.

### 20-Meters

The 20-meter section of the beam uses 2 elements in a reflector-driver arrangement. I specifically selected the boom length to preclude the effective use of a director, since a 3-element Yagi with a wide 50-Ω bandwidth is close to 24' long. The 2-elements in the model provide anticipated performance, as shown by the sample free-space E-plane patterns in **Fig. 2**. **Table 2** provides sample performance data that goes with the free-space patterns. The table includes a Δ-column to record the amount of change of values across the 20-meter band.

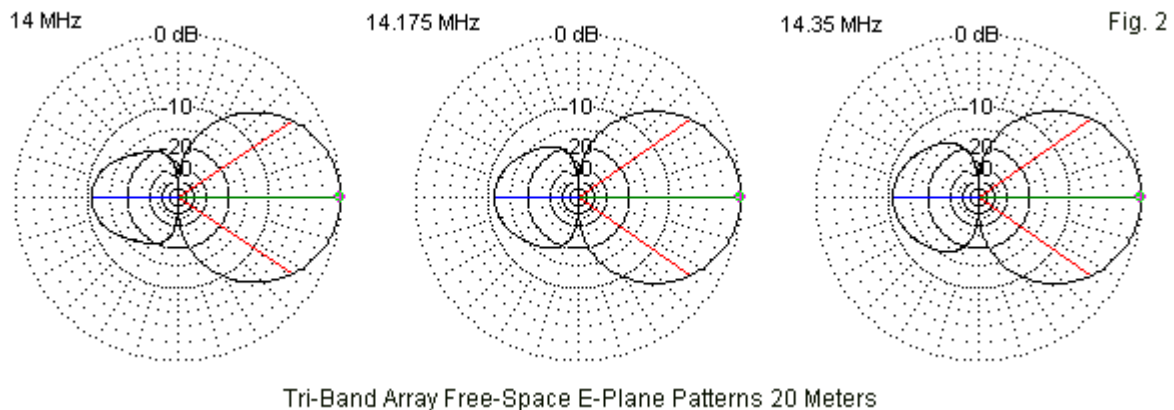
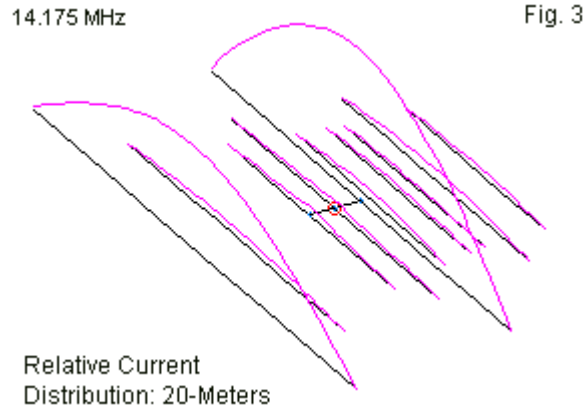

Table 2. 20-meter performance

20 Meters	14.0	14.175	14.35	Δ
Frequency	14.0	14.175	14.35	Δ
Free-space Gain dBi	6.55	6.25	5.98	0.57
Front-to-back ratio dB	10.82	11.32	10.96	0.50
Feedpoint Z (R +/- jX Ω)	40.6 - j7.3	54.8 - j1.7	70.4 + j1.5	29.8 + j8.8
50-Ω SWR	1.30	1.10	1.41	

For any tri-band array, one key is to base the low-band design on a broad bandwidth monoband design. The selected array for the lowest band will undergo the least influence by

the presence of elements for other bands. Even the feed system forces on the designer only modest adjustments to account for the parallel impedance situation. **Fig. 3** shows the relative current magnitude distribution among the elements at 14.175 MHz. Perhaps most notable in the graphic is the extremely low level of activity on the upper band elements.



The current distribution curves provide us with a justification for treating 20-meter performance as a function of just the 2 active elements. However, these elements occupy only 127" of the 215" total boom length. Hence, expecting 18' boom performance on 20 meters would be unreasonable. It is much more reasonable to compare the performance on the lowest band with a monoband 2-element reflector-driver array, such as the one outlined in **Fig. 4**

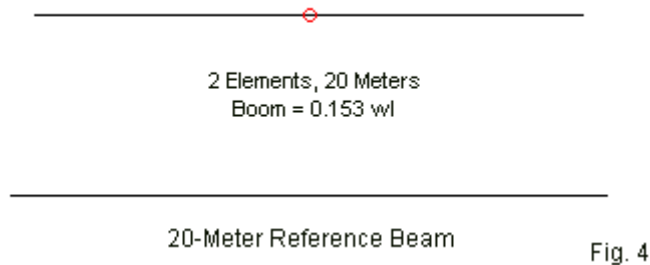

Note that the spacing between the elements—the boom length—for the monoband beam is  $0.153\lambda$ , the same as for the two 20-meter elements in the tri-band array. For the reference 2-element Yagi, **Table 3** provides modeled free-space performance data.

Table 3. Reference Monoband Yagi 20-meter performance

20 Meters	14.0	14.175	14.35	$\Delta$
Frequency	14.0	14.175	14.35	$\Delta$
Free-space Gain dBi	6.45	6.15	5.88	0.57
Front-to-back ratio dB	10.52	10.93	10.58	0.41
Feedpoint Z (R +/- jX $\Omega$ )	37.9 - j9.4	44.8 + j4.0	51.3 + j16.3	13.4 + j26.0
50- $\Omega$ SWR	1.42	1.15	1.39	

In a very cursory way, the tabular values appear very comparable to the data for the 20-meter section of the tri-band antenna. However, there are some slight but interesting differences that deserve attention. For example, the tri-band gain and front-to-back values are slightly higher than the values for the monoband beam. The differences are not operationally

significant, but they are systematic. **Fig. 5** overlays the frequency sweep information for both antenna models for ready comparison.

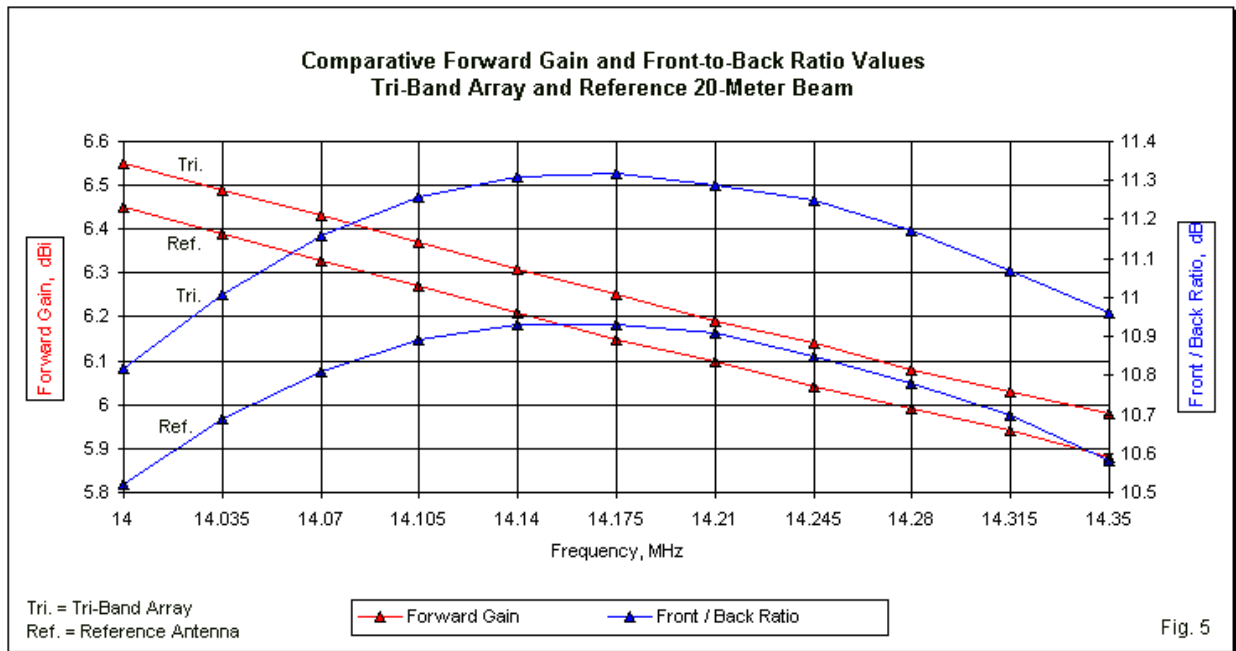

Please attend closely to the values on both Y-axes so that you do not inflate the differences beyond their real limits. The explanation for the higher values in the tri-band array lies in the low level of current activity on the forward elements. In a minuscule way, they act as directors for the 20-meter elements in a phenomenon known as forward stagger. Some beam designs make good use of forward stagger, but in this instance, its existence is somewhat incidental to the tri-band array's 20-meter performance.

Also worth passing notice is the difference in the behavior of the feedpoint impedance between the 20-meter tri-band section and the monoband beam. The tri-band section shows a relatively large swing in resistance with a small change in reactance, while the monoband beam shows just the opposite. The difference arises from the complex impedance situation at the tri-band feedpoint. The effect on the 50-Ω SWR across the band is very small, as shown in the overlaid curves in **Fig. 6**. In both cases, the SWR does not rise to 1.5:1 anywhere within the 20-meter band.

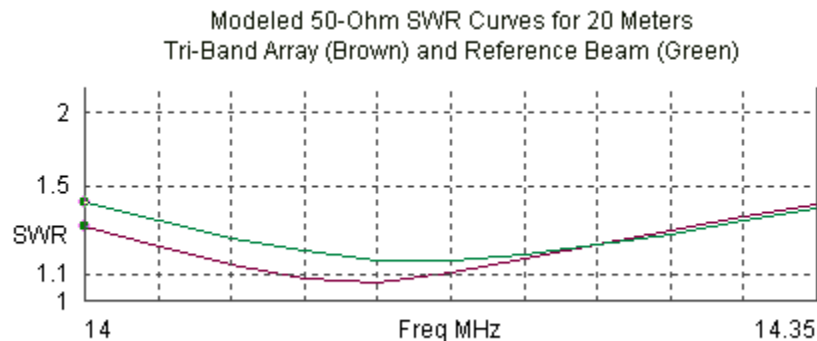

The low-band section of a multi-band Yagi, then, is the core of the design. As one designs the elements for other bands near the 20-meter elements, the low-band elements exert far more influence than they receive from those upper-band elements. In general, the low-band elements—treated as a monoband beam—should have satisfactory performance on their own and should show a natural feedpoint impedance value close to 50  $\Omega$ . This fact sets some limitations to array design. For example, a 3-element 20-meter Yagi with both significantly better performance and a natural 50- $\Omega$  feedpoint impedance would require about 12' between the reflector and the driver. In some commercial designs, we find somewhat closer spacing as the beam makers accept somewhat lower feedpoint impedance values that still yield SWR values of less than 2:1 relative to a 50- $\Omega$  standard. Even with somewhat closer reflector-to-driver spacing, an adequate director would still lie beyond the 18' limit set for this array. As well, had we opted to try for such an arrangement, the results would not be applicable to smaller modern arrays that use 2-element performance on both 20 and 15 meters.

### 15 Meters

Performance on bands above the lowest in a multi-band Yagis of contemporary design tend to suffer somewhat in terms of both gain and operating bandwidth. The present design manages very good performance for the effective boom length (153" or 0.275- $\lambda$ ) occupied by the 3 elements for 15 meters. The free-space E-plane plots for the band, in **Fig. 7**, all show very well behaved patterns. **Table 4** confirms the impression left by the patterns with sampled data from the array model.

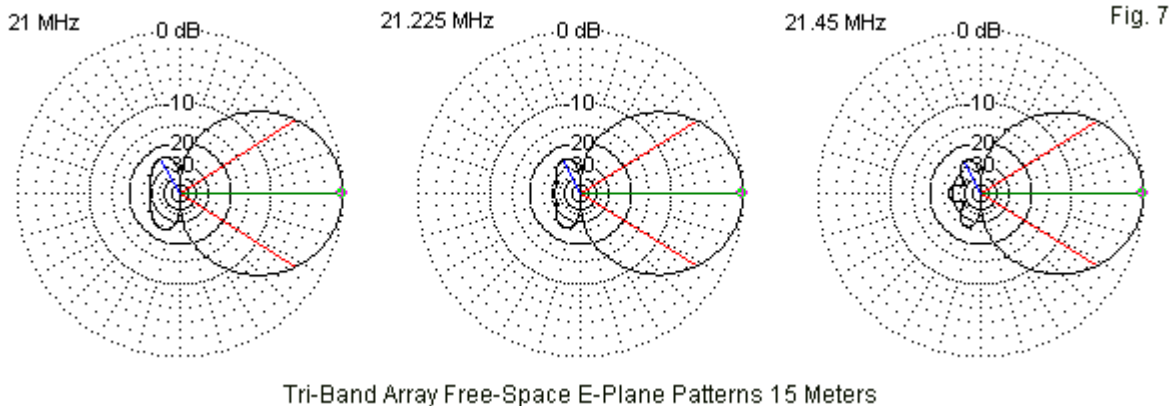
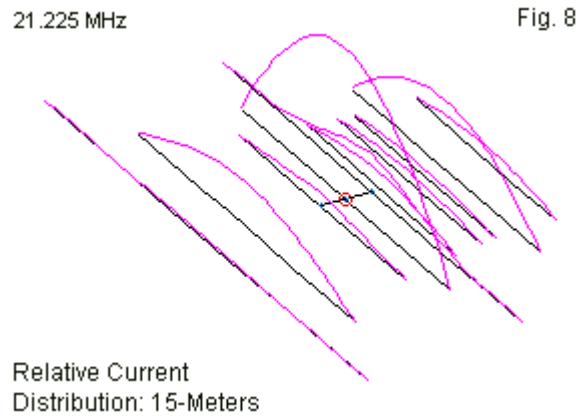

Table 4. 15-meter performance

15 Meters	21.0	21.225	21.45	$\Delta$
Frequency	21.0	21.225	21.45	$\Delta$
Free-space Gain dBi	7.50	7.53	7.59	0.09
Front-to-back ratio dB	29.25	31.18	27.83	3.35
Feedpoint Z (R +/- jX $\Omega$ )	37.5 - j4.1	50.5 + j3.3	67.4 + j11.8	29.9 + j15.9
50- $\Omega$ SWR	1.35	1.07	1.43	

One significant reason why the present design obtains full performance from its elements is the absence of a 20-meter director forward of the 15-meter director. A higher band portion of an array should always have a director ahead of a director for a lower band to control the current distribution and therefore the pattern. A 20-meter director added to the 2 elements for that band would have ended up ahead of the existing 15-meter director and acted as a reflector element on 15, limiting the forward gain on the higher band. A forward director is as much a control

element as it is an element to add gain to an array. **Fig. 1** shows a 10-meter director ahead of the 15-meter director to achieve this goal on the highest band covered by the array.



The relative current magnitude distribution curves in **Fig. 8** show the dominance of the 15-meter elements on that band. The current magnitude on some of the other elements, while low, is not at the wholly insignificant level. The 20-meter driver element shows some current activity, but a close inspection of the curve shows that it approaches (but does not reach) zero at positions parallel to the limits of the 15-meter driver. The 10-meter directors also show a low but non-negligible current level of varying magnitudes. We might expect these elements to provide a forward stagger effect that might be greater than we found on 20 meters. To determine whether this is a correct surmise and whether the performance data is reasonable for the 15-meter boom length, we need a reference monoband beam. It must not only have a comparable boom length, but also be configured in roughly the same way as the elements in the multi-band array. **Fig. 9** outlines the candidate, while **Table 5** samples the free-space performance..

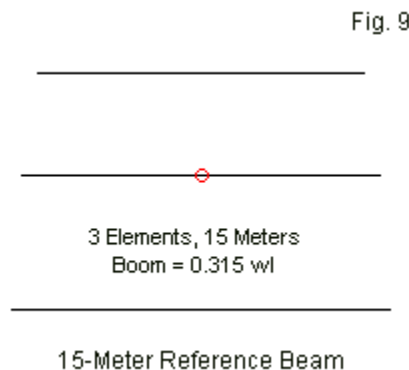

Table 5. Reference monoband Yagi 15-meter performance

15 Meters	21.0	21.225	21.45	$\Delta$
Frequency	21.0	21.225	21.45	$\Delta$
Free-space Gain dBi	7.19	7.28	7.42	0.23
Front-to-back ratio dB	22.76	27.57	27.09	4.81
Feedpoint Z (R +/- jX $\Omega$ )	46.2 - j7.9	43.6 - j0.5	39.9 + j7.9	6.3 + j15.8
50- $\Omega$ SWR	1.20	1.15	1.33	

Both the gain and the front-to-back values for the reference beam are slightly lower than those for the 15-meter section of the tri-band array, although the differences fall below operational significance. It would be very difficult for any operator to detect a gain difference of 0.3 dB, although the front-to-back differential might be detectable at the low end of the band. Interestingly, the monoband version of the beam is actually longer than the 15-meter section of the tri-band array, but the difference lies mostly in the spacing from the driver to the reflector. Once we add directors to a Yagi, they tend to control both the forward gain and the front-to-back ratio, with only minor contributions from the reflector. The chief function of the reflector is to establish the basic feedpoint impedance of the array. In the tri-band array, with its direct drive system and parallel combination of impedances at the connection with the main feedline, the spacing is shorter so that the composite feedpoint impedance falls close to 50  $\Omega$ .

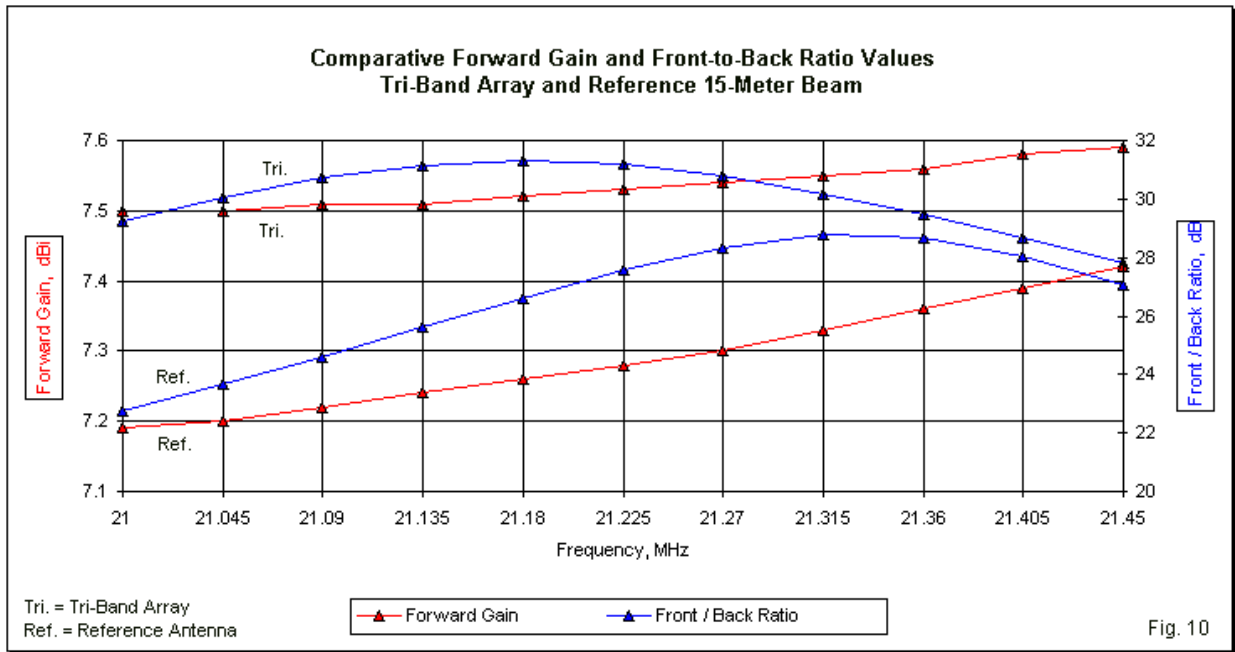

Fig. 10

The difference in the feed systems between the monoband Yagi and its tri-band counterpart shows up in the manner in which the feedpoint resistance and reactance vary across the band. The tri-band 15-meter impedance values show nearly 30  $\Omega$  of difference across the band, while the monoband beam—expressly designed for a broad SWR curve—shows only a 6- $\Omega$  difference.

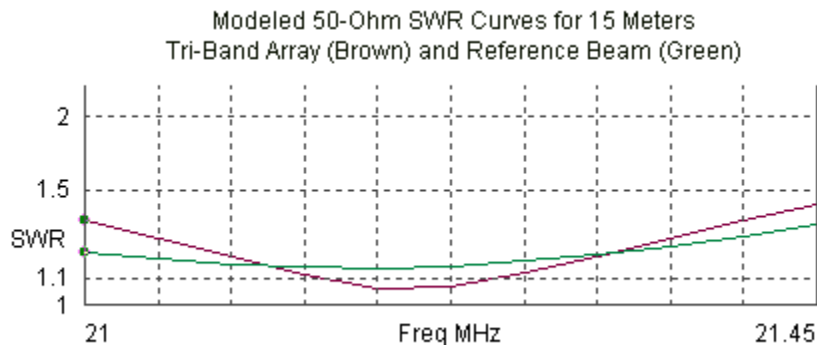

Fig. 11



As shown in **Fig. 11**, the effects of the off-band impedance values results in a steeper SWR curve in the tri-band beam. However, the curve is not so steep as to result in an SWR value of 1.5:1 anywhere in the band.

One goal of the design has been to achieve broadband performance in more than just the SWR category. The  $\Delta$ -values suggest that the 15-meter effort has succeeded, with less than 0.1-dB difference in forward gain across the band. As well, the front-to-back ratio variation is less in the tri-band elements than in the monoband beam, although one might tweak those numbers with further element adjustments. Part of the success derives from the selection of a broadband monoband design to form the basis for this section. Another part results from having no lower-band element ahead of the 15-meter director.

### 10 Meters

In many contemporary multi-band designs, the highest band presents the greatest challenge. Even the 18' boom, short by commercial standards, is a fairly long boom for 10 meters, even though the 10-meter elements occupy only about 10' of the space. On a 10' boom, we would normally see only about 3 10-meter elements. However, the tri-band design has no reflector element, that is, a rearward parasitic element. The rearmost element is the fed driver. Forward of the element, we find a total of 4 directors, each with a specific task. Nevertheless, the sum of the element s is a set of well-controlled patterns, as shown in the free-space E-plane plots in **Fig. 12**. **Table 6** provides sample data to accompany the patterns.

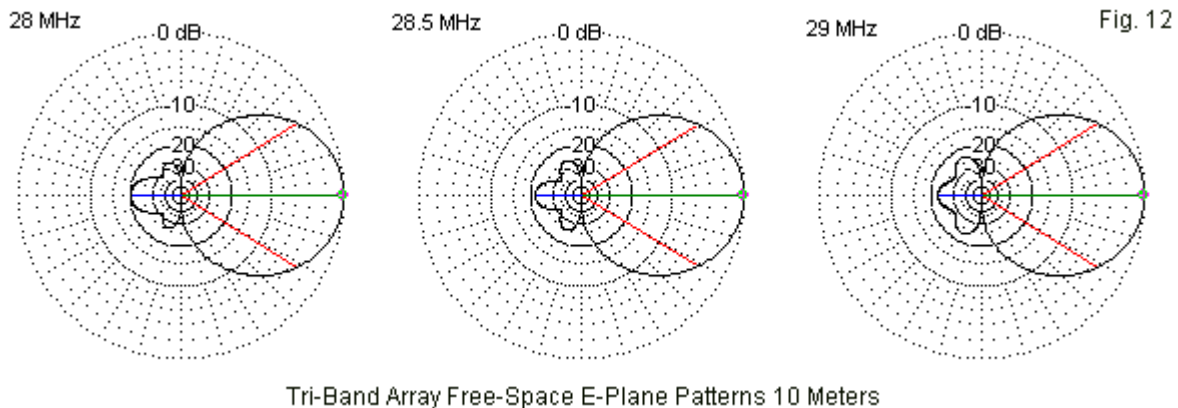

Table 6. 10-meter performance

10 Meters	28.0	28.5	29.0	$\Delta$
Frequency	28.0	28.5	29.0	$\Delta$
Free-space Gain dBi	7.67	8.19	8.37	0.70
Front-to-back ratio dB	20.10	21.58	22.56	2.46
Feedpoint Z (R +/- jX $\Omega$ )	42.3 - j10.6	50.3 + j0.6	54.2 + j20.3	11.9 + j30.9
50- $\Omega$ SWR	1.33	1.01	1.48	

Compared to many commercial designs, the present tri-band array gives very broadband 10-meter coverage. To achieve this goal, it uses more directors than are common in most arrays. One of the enduring half-truths that pervade modern Yagi design is that gain is more a function of boom length than it is of the number of elements. This idea is correct but incomplete. It has given license to those who would try to obtain the most gain from the least weight of aluminum, regardless of other consequences. One consequence is a narrow

operating bandwidth in all of the major performance categories. The judicious addition of an extra element may not increase the array gain if we do not lengthen the boom, but it may spread the performance over a wider frequency span.

In the present design, the directors serve not only to create a wider operating bandwidth, but as well to control the influence of lower-band elements. To provide a sense of the need for them, **Fig. 13** provides an expanded view of the relative current magnitude curves on the elements at 28.5 MHz. A smaller graphic would have obscured the complex maze of current levels.

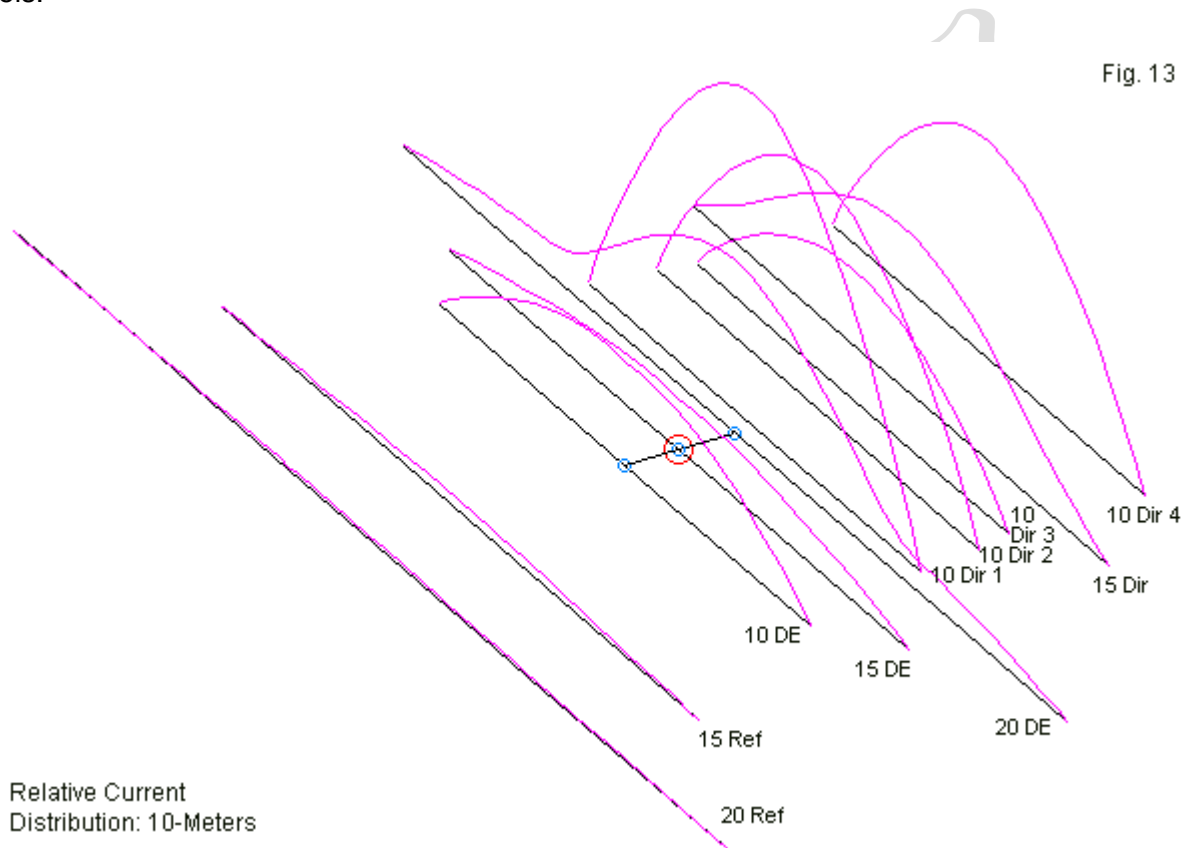

Fig. 13

The elements to the rear of the 10-meter driver are relatively inert. However, every element forward of the 10-meter driver is active, regardless of its primary band. For example, the 15-meter director shows very high activity and would tend to limit 10-meter gain without the 10-meter director (#4) in the forward-most position. In addition, the director (#3) immediately to the rear of the 15-meter director serves primarily as a control element, resulting in the tapering of the current curve on the lower band element better to fit 10 meters. Director #2, with its higher current peak, serves as a primary element contributing to the forward gain and the front-to-back ratio values.

Director #1 has an interesting role to play. Since the element is parasitic, without direct connection to the energy source, we classify it as a director. However, note the exceptionally high current magnitude on the element. In contrast, the 10-meter driven element has a much lower current magnitude. In fact, the 20-meter driven element shows a higher current magnitude. Let's alter our view of the 10-meter elements. We might consider the element designated as the driven element to be a driven reflector element. The element designated as

Director #1 becomes the actual driven element controlling beam behavior. It receives energy parasitically from the collection of driven elements, not the least of which is the 20-meter driver with its truncated current magnitude curve. Under this view, the director becomes a secondary driver, a relatively common design element in many broadband beams. Treating director #1 as a secondary driver reduces the number of parasitic directors serving both control and performance enhancement functions to three.

Regardless of which view we take of the element functions, we still must answer the question of whether the 10-meter section obtains reasonably good performance from the 126" occupied by the 10-meter elements. Unlike both 20 and 15 meters, we have no monoband analog to the element structure used for 10 meters in the tri-band array. From my files, I found only a 4-element monoband array on a 156" (0.376- $\lambda$ ) boom (in contrast to the 0.3- $\lambda$  boom for the 10-meter elements on the tri-band beam). It uses a reflector, two closely spaced drivers (a primary fed driver and a secondary parasitic driver), and a director. **Fig. 14** shows the outline. What it shares in common with the 10-meter section of the tri-band Yagi is a design tailored to broadband performance.

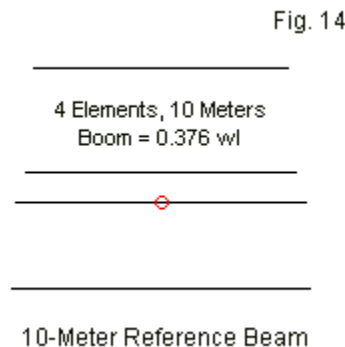

The 4-element broadband design provides us with some interesting sample data, as shown in **Table 7**.

Table 7. Reference monoband Yagi: 10-meter performance

10 Meters				
Frequency	28.0	28.5	29.0	$\Delta$
Free-space Gain dBi	8.03	8.15	8.33	0.30
Front-to-back ratio dB	20.83	23.34	18.76	4.58
Feedpoint Z (R +/- jX $\Omega$ )	50.1 - j6.5	53.4 - j0.5	52.6 + j2.3	3.3 + j8.8
50- $\Omega$ SWR	1.14	1.07	1.07	

The reference beam is not a pure analog of the 10-meter section of the tri-band beam, since it does not have the same general structure. However, it can serve in a general way to evaluate the 10-meter performance of the tri-band array. **Fig. 15** provides overlaid graphs of the gain and front-to-back figures for 28 to 29 MHz. We may immediately notice that the reference beam has a flatter gain curve. However, the rate of change of the tri-band section is about the same as the 20-meter section of the beam, which is still quite flat compared to conventional Yagi designs. The reference beam gives up a stable front-to-back ratio to obtain the flat gain value. The 10-meter section of the tri-band array does the reverse: it shows a much flatter front-to-back curve, although the gain curve has a noticeable slope. If we accept the trade-offs, the two beams have comparable performance.

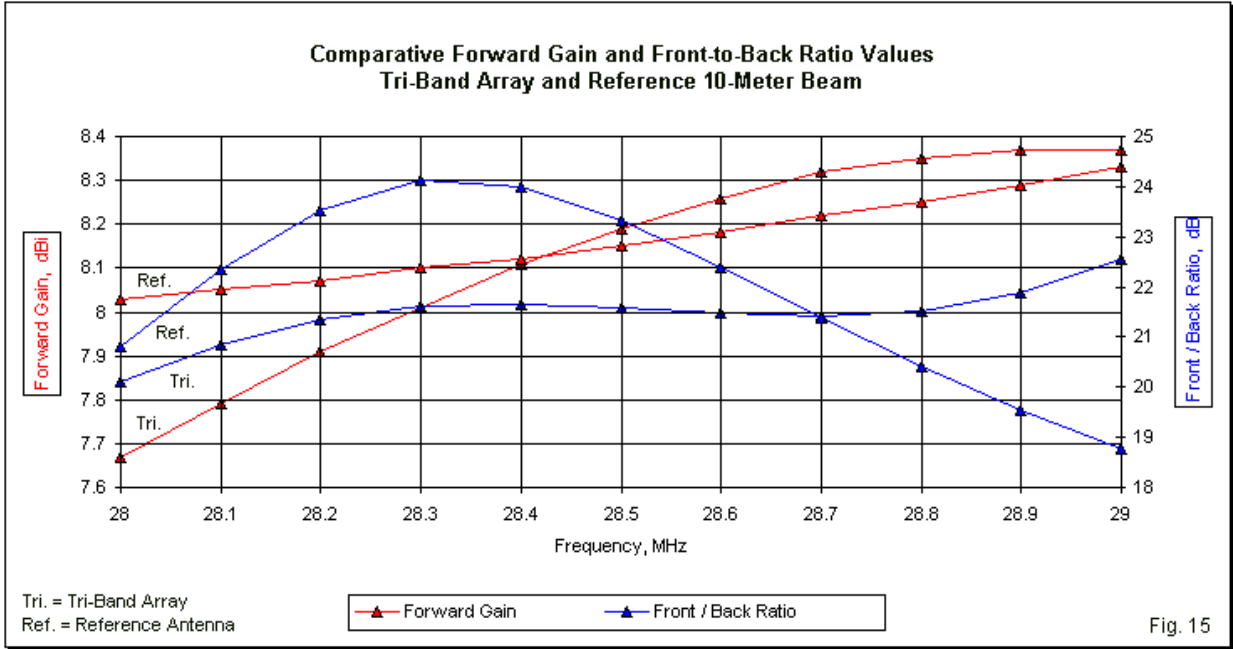

Fig. 15

Where the tri-band 10-meter section cannot match the special wide-band reference antenna in the feedpoint impedance category. As shown in the table and in **Fig. 16**, the reference antenna achieves a remarkably flat and low 50-Ohm SWR curve. (Should anyone be interested, the full structural details of the reference wide-band 10-meter beam, including an EZNEC model, appear in *Wide-Band Yagi Notes*, available through *antenneX*.) Nevertheless, the tri-band Yagi section has an SWR curve that matches those for the lower bands. When thinking in multi-band Yagi terms, this curve is very flat, since most commercial offerings are satisfied with band-edge values of 2:1. The 10-meter section in the present design does not reach SWR values of 1.5:1.

Modeled 50-Ohm SWR Curves for 10 Meters  
Tri-Band Array (Brown) and Reference Beam (Green)

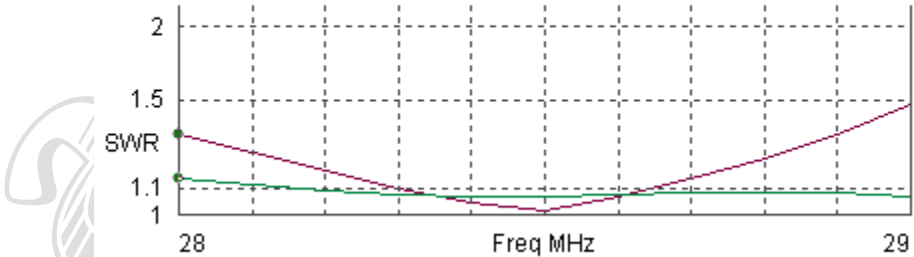

Fig. 16

One of the key reasons for the wide-band performance of the tri-band array 10-meter section lies in the use of the seemingly large number of directors. Each director serves at least one function that contributes to achieving the performance and impedance values across the first MHz of 10 meters. Actually, each director serves multiple functions, since—for example—we could not derive all of the forward gain without the control directors that overcome the influence of the 15-meter director. In essence, the design makes a case for not trying to work with the absolute minimum number of directors for a certain peak gain value. Rather,

judiciously populating the director area can result in wide-band performance. More significantly, the present design passes the test of providing very reasonable performance for the length of boom that the band's elements occupy.

#### *Summary Notes about the Tri-Band Design*

In the commercial market, we would never find a tri-band beam using anything like the present design. Smaller designs exist, using 2 elements on 20, 2 on 15, and perhaps 3 elements on 10 meters. As well, larger designs also exist, with most in the 24 to 32 foot range. The added space allows the designer to include 3 elements for 20 meters and at least 3 elements for 15 meters. The 10-meter section will contain enough elements to place the most forward of them beyond the most forward lower-band elements.

The chief drawback of the design that we have used as a study sample lies in the 2-dB difference in forward gain between the lowest and the highest band covered. For most amateur operators, this differential would be too large, especially in periods of low sunspot activity, when 10 meters hardly ever opens at all. The wide-band 2-element 20-meter section also suffers from the low front-to-back ratio that accompanies a driver-reflector arrangement.

On the other hand, the sample design does achieve very good wide-band performance. The direct-drive feed system contributes to that performance, especially in terms of the feedpoint impedance values on each band. As a supplemental benefit, the direct-drive system places enough space between elements wherever they cluster to prevent unwanted wind effects. In a given wind, the elements will flex at differential rates, according to their length and element-diameter taper schedule. Too tight a spacing between elements may require element spacers about half way outward from the center to ensure that the element do not touch and do not even flex enough in opposite directions to noticeably alter performance.

In addition, the selection of basic lower-band monoband designs that have wide-band characteristics aids that portion of the array, while the willingness to use all of the 10-meter directors needed by the design helps the performance on the highest band. Most commercially available contemporary tri-band designs adhere to the lower-band convention, but you may discover a bit of a minimalist tendency on 10 meters, as the designs try to reduce the number of directors required for smooth wide-band performance in all categories.

#### *Summary Notes on Forming Reasonable Expectations of Tri-Band Arrays*

The design sample has only served to alert us to some of the things that we should investigate and learn when evaluating a tri-band array, especially if we are about to spend between \$800 and \$1400 for an antenna. When developing reasonable expectations, we need first to determine the boom length devoted to the elements for each band. In most cases, we may set aside any forward stagger effects that emerge from the presence of higher-band elements ahead of lower-band elements, since the effects are small. The boom length devoted to the elements for a give band give us a means of estimating the appropriate gain level on each band.

Second, we need to examine monoband beams of a comparable length and, if possible, configuration to see what their gain values are. In the process, we should not confuse wide-band with other designs. Wide-band designs also tend to have feedpoint impedance values close to 50  $\Omega$ , which is critical to direct-drive systems using a low-impedance connecting line among the drivers. (Open-sleeve coupling designs are not as critically dependent on this need

except on the lowest band, to which the feedline normally connects.) A 24' boom for 20 meters may carry 3 elements in at least two different ways. In one configuration, we may obtain about 8 dBi free-space gain, but with a feedpoint impedance in the mid-20- $\Omega$  range. The same boom, with different spacing values between elements, may carry a 50- $\Omega$  wide-band Yagi, but with a maximum gain just over 7 dBi. Since operating bandwidth tends to decrease for a set number of elements as the operating frequency increases (that is, as we move to a higher band among those covered), the use of wide-band designs becomes more critical to the success of a tri-band array.

Third, we need to obtain for both any reference antennas and for the array under evaluation frequency sweep curves for all of the major performance categories. This part of the process may require going well beyond commercially available specification sheets. In many cases, these sheets will list only single values for gain and for the front-to-back ratio—often either the peak value or the average value for a given band. As we have seen, knowing the amount of change in those values across a band is very useful in evaluating whether an array will meet a particular set of operating needs.

In addition, be certain to obtain the conditions under which measurements or modeling data are derived. For example, one maker habitually uses lossless elements in its models. Hence, its gain values are always slightly optimistic relative to reality. Another maker takes impedance readings at the lower end of a standard length of 50- $\Omega$  coaxial cable rather than listing the impedance values at the antenna terminals. Although this procedure may reflect what a user might expect in operation, it prevents us from directly comparing that company's offerings with those of another company that lists the impedance derived from antenna terminal measurements or from the design model data. There are methods—using one of the available transmission-line programs—for back-calculating the true antenna terminal impedance, and if we are serious in our evaluation efforts, we shall use them.

Contemporary tri-band beam design has produced some arrays that have become classics, and the designs are undergoing relatively continuous development. As the designs take on more complex appearances, we need to develop means of evaluating them. The first step is to find a procedure that will yield both reasonable expectations and a way to see if the beam fulfills them. The procedure outlined with our design sample shows only one way to that goal. Still, if we had no way in the past, one way can be very useful. The 20<sup>th</sup>-century poet Ogden Nash titled one volume of his works, *You Can't Get There from Here*. Now you can.

**© All Rights Reserved World Wide  
ANTENNEX LLC**