

Half-Length Dipoles (for 40 Meters) Part 1: The Full-Length Standard

L. B. Cebik, W4RNL

Below 20 meters, full-length dipoles (and other antennas based on the dipole) present space problems. For many amateurs, such antennas are simply too long to fit within the modern urban and suburban yards. So the antenna builder begins to think of ways to shorten the dipole. The questions surrounding shortened antennas are complex. Some involve performance levels compared to the full-length dipole. Others concern the relative efficiency of antennas that use different means of shortening. Another group of questions focus on the mechanical issues created by various methods of shortening. Moreover, there are auxiliary matters, such as matching the shortened antenna to one of the standard feedlines in common use.

To explore these questions in a somewhat systematic manner, we shall pick a single antenna length on a single amateur band. 40 meters (7.0 to 7.3 MHz in the U.S.) is handy, since the average dipole length is in the vicinity of 67', just on the verge of fitting or not fitting a typical back yard. Let's use a half-length dipole and set its length at a fixed value of about 33' for our explorations. Our antennas will use AWG #12 (0.0808" diameter) copper wire, although we shall occasionally look at fatter elements for special purposes. With these simple premises, we can examine a myriad of ways of shortening dipoles, including but not limited to, folding back the elements, using inductive loads at the dipole center or along the element length, using end "hat" loads or element extensions, and employing U shapes. Each alternative method of shortening the length of a dipole has its own cluster of variations, its own set of issues, and its own set of consequences.

Ultimately, we shall want to be able to make a set of comparative evaluations of the different methods of shorten a dipole to about half-length. To make sense of the comparisons, we shall need a standard against which to measure the changes that we encounter. The logical standard for assessing a half-length dipole is a full-length dipole. This first episode in our journey will deal solely with full-length 40-meter dipoles. The more we understand the practical electrical and physical properties of a full-length dipole, the easier it will become to understand what we gain or lose by shrinking the length by half.

The Basic Properties of a Full-Length 40-Meter Dipole

What we loosely label as a dipole is actually a special version of the dipole. A dipole is any antenna that has a current distribution that shows a single peak value at its center. Conversely, there are two voltage peak values, one at either end of the antenna. This condition can exist only for antennas that are electrically $\frac{1}{2} \lambda$ or shorter. Once the antenna length exceeds $\frac{1}{2} \lambda$, we find multiple current peaks along its length.

A second special feature of what we call a dipole is that the feedpoint is at the element center. There are ways of feeding elements of the same length off center or even at the end. But our common notion of a dipole includes the idea that it is center fed. A third feature is that the antenna be resonant, in other words, that the feedpoint impedance at the design frequency be purely resistive. In the models that we shall use, we may define a resonant condition as a feedpoint impedance with less than 1- Ω of reactance (either inductive or capacitive). We shall use the arithmetic mid-band point of 40 meters (7.15 MHz) as the design frequency throughout.

As a result of these considerations, what we simply call a dipole is actually a center-fed resonant $\frac{1}{2} \lambda$ dipole. **Fig. 1** shows a typical dipole as installed. In one or another form, we find end insulators to isolate the element from its supporting structure. As well, we find a gap at the element center. We connect the feedline (usually but not necessarily a coaxial cable) in series with the element, with one line conductor going to one side of the element, and, of course, the other feedline conductor going to the other side of the element. A full installation might include other features, such as a lightning protection device or a common-mode current attenuator. However, the sketch includes only the essential electrical elements to set up the dipole.

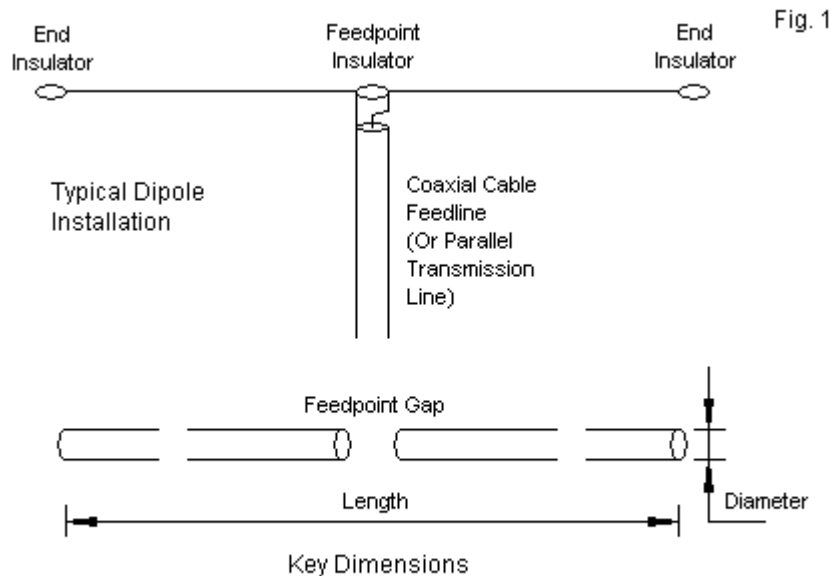

Basic Practical Properties of a Dipole Antenna

We specify a dipole in terms of its length and the element diameter. To appreciate the importance of how these two facets of a resonant dipole interact, let's set up in a free-space environment resonant dipoles using various diameter elements. **Table 1** shows some typical examples, ranging from relatively thin AWG #14 copper wire to very heavy 2" aluminum tubing. Operationally, any of these dipoles would give equivalent service, but the fine shades of numerical difference among the entries have a story to tell.

Table 1. The relationship between a resonant dipole's length and diameter in free space

Material	Diameter	Length		Feedpoint Z R +/- jX Ω	Max. Gain dBi
		Feet	Inches		
Copper	#14 (0.0621")	66.92	803.0	73.5 + j0.2	2.05
Copper	#12 (0.0808")	66.87	802.4	73.2 - j0.0	2.07
Aluminum	0.5"	66.33	796.0	72.2 - j0.1	2.12
Aluminum	1.0"	66.00	792.0	72.0 - j0.4	2.13
Aluminum	2.0"	65.60	787.2	72.0 - j0.5	2.13

An electrical half-wavelength at 7.15 MHz is actually 68.78' (825.37"). All of the entries are shorter than this value. Two factors contribute to the shorter lengths required of real dipoles to achieve resonance at the design frequency. The major factor in most cases is the phenomenon

called end effect that results from the slight alteration of fields due to the area that forms the wire end. A second factor is the conductivity of the element (or its resistivity). All common metals have a finite conductivity. The lower the conductivity, the shorter becomes the length of a resonant dipole. Copper and aluminum in the common diameters that we use for dipole elements have very high conductivity values and thus contribute little to antenna shortening.

However, the actual conductivity of the element is also a function of the element diameter. Increasing the diameter increases the surface area of the element. Skin effect forces currents to exist near the surface of the antenna at RF frequencies. The higher the frequency, the thinner the region of the element in which we find significant current. Hence, hollow tubing functions just as well as solid wire for the same material and diameter. Copper-bonded wire has a steel core for strength, but the core does not enter into the electrical operation of the wire in antenna applications. The surface layer of copper is thick enough in quality versions of the wire to contain virtually all of the electrical activity.

End effect tends to dominate the factors influencing the resonant length of a 40-meter dipole. Therefore, as we increase the element diameter, we find a decrease in the resonant length. Physically shorter antennas also show lower feedpoint impedance values, and we see this phenomenon at work in the table's entries. Fatter elements have less loss than thinner ones, and so we find that the free-space maximum gain figure increases as we increase the element diameter. However, note that the gain value levels off. Gain also decreases as we shorten a resonant dipole, so we have a balance between the element diameter with lower losses and the element length with its natural variation in gain. The gain numbers in the table are noticeable, but would not result in any detectable difference in operational performance.

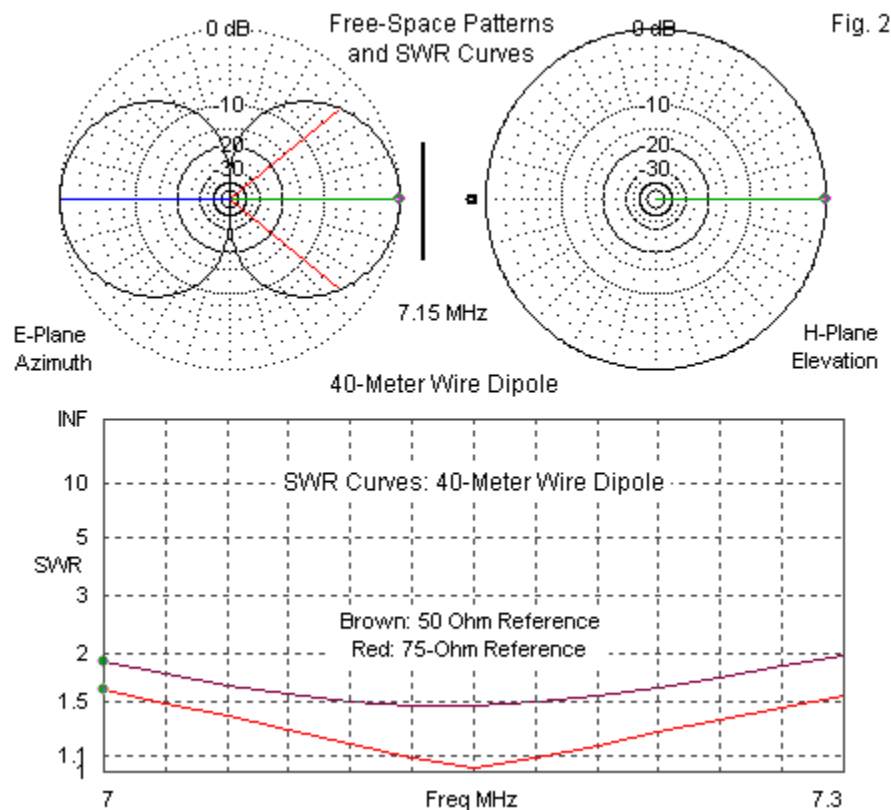

Fig. 2 shows the free-space E-plane and H-plane patterns for the dipole in free space. An E-plane pattern for a linear antenna element is in the plane of the wire, while the H-plane looks at the antenna element from its end. In free space, with no ground reflections, the H-plane pattern is perfectly circular. A $\frac{1}{2} \lambda$ dipole has almost no far-field radiation off its ends, so we obtain an E-plane pattern with the familiar figure-8 shape. The reduction in radiation off the element ends and the increase in radiation broadside to the wire give the antenna its gain value over an isotropic source of radiation. We measure the gain in dB relative to an isotropic source that radiates equally well on all possible directions, hence, the values in dBi.

The figure also shows the SWR curves for the free-space version of the dipole. The 75- Ω curve uses a reference value close to the resonant impedance of the antenna, so the minimum SWR value goes down to 1:1. As we add either inductive reactance (above the center frequency) or capacitive reactance (below the center frequency) to the feedpoint impedance, the SWR goes up. The resistive component of the impedance is also changing: it increases as the frequency increases. However, the rate of change of resistance for a common dipole is usually much less than the rate of change of the reactance. So the reactance tends to play a greater role in the dipole's SWR increase away from resonance.

The SWR reference impedance represents the value of the source impedance, in most cases, the characteristic impedance of the feedline that we attach to the antenna feedpoint. Since most amateurs will connect a 50- Ω coaxial cable to the dipole, the figure also shows the SWR with a 50- Ω reference. Note that the curve has a minimum value that is greater than 1:1. The curve barely manages to stay within the common amateur limit of 2:1 across the band. However, most amateurs do not measure the SWR at the antenna terminals. Instead, they measure the SWR at the equipment end of a length of feedline. We shall eventually look at that situation.

The feedpoint SWR and the resonant condition of the antenna do not affect the element's ability to radiate. The element length—and to some degree, its diameter—determine the radiation pattern strength and shape. Having a resonant feedpoint impedance and a low SWR are merely conveniences that allow the antenna builder to create a simple but effective basic antenna installation. There are many other types of linear antenna elements, such as the 1.25λ extended double Zepp, that operate efficiently with a feedpoint impedance far from resonance and with a relatively high SWR on a low-loss parallel feedline.

The feedpoint gap shown in the dipole sketch calls for special attention. The gap is part of the overall length of the element. A practical feedpoint insulator might range from $\frac{1}{2}$ " to perhaps 6" on 40 meters. The actual gap is simply the spacing between the two conductors of the feedline. Whatever the mechanical gap that we create, we run leads from each side to the feedline conductors. These leads are properly part of the antenna element. All antenna specifications include the feedline gap as part of the length figure for the total element.

From this point forward in this part, we shall work only with the AWG #12 copper wire version of the dipole. We shall retain its free-space resonant length of 66.87' (802.4"), but we shall next change the environment. We shall place the antenna over ground, more specifically, "average" ground with a conductivity of 0.005 S/m and a permittivity or relative dielectric constant of 13. **Fig. 3** shows the general situation for a dipole above real ground. Note that the sketch shows the antenna height and the ground quality as significant factors, but initially, we shall work only with the middle level of ground quality using the antenna that we set to resonance in free space.

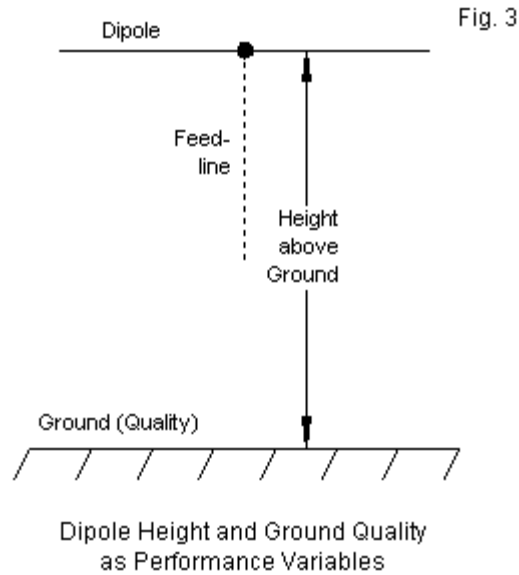

The maximum gain and the feedpoint impedance of a dipole systematically change as we change the height of an antenna above ground, measuring the height in terms of a wavelength. **Table 2** shows the changing values for heights of 0.05λ up to 1.0λ on 0.05λ increments. For easier reference, **Fig. 4** graphs the pattern of resistance and reactance values, while **Fig. 5** traces the changes in the dipole's gain and its take-off (TO) angle.

Dipole Performance as a Function of Height above Ground					
AWG #12 Copper Wire			Average Ground		7.15 MHz
Height wl	Height ft	Gain dBi	TO deg	Resist	React
0.05	6.88	0.31	88	58.2	13.2
0.10	13.75	4.40	88	54.1	17.0
0.15	20.61	5.84	88	63.6	22.5
0.20	27.48	6.12	88	75.8	21.7
0.25	34.35	5.92	59	85.2	15.1
0.30	41.22	5.90	47	89.3	5.4
0.35	48.09	6.10	39	87.8	-3.9
0.40	54.95	6.50	35	82.2	-10.2
0.45	61.82	7.00	30	74.7	-12.2
0.50	68.69	7.51	28	68.0	-10.0
0.55	75.56	7.86	25	64.0	-4.9
0.60	82.43	7.97	23	63.6	1.2
0.65	89.30	7.85	21	66.6	6.0
0.70	96.16	7.60	20	71.4	8.2
0.75	103.03	7.34	18	76.3	7.2
0.80	109.90	7.18	17	79.5	3.8
0.85	116.77	7.16	16	80.1	-0.5
0.90	123.64	7.28	15	78.2	-4.2
0.95	130.50	7.49	15	74.8	-6.1
1.00	137.37	7.74	14	71.1	-5.7
Notes:	Gain dBi: maximum gain in dBi at take-off (TO) angle				
	TO deg: elevation of maximum gain in degrees				
	Resist: feedpoint resistance in Ohms				
	React: feedpoint reactance in Ohms				Table 2

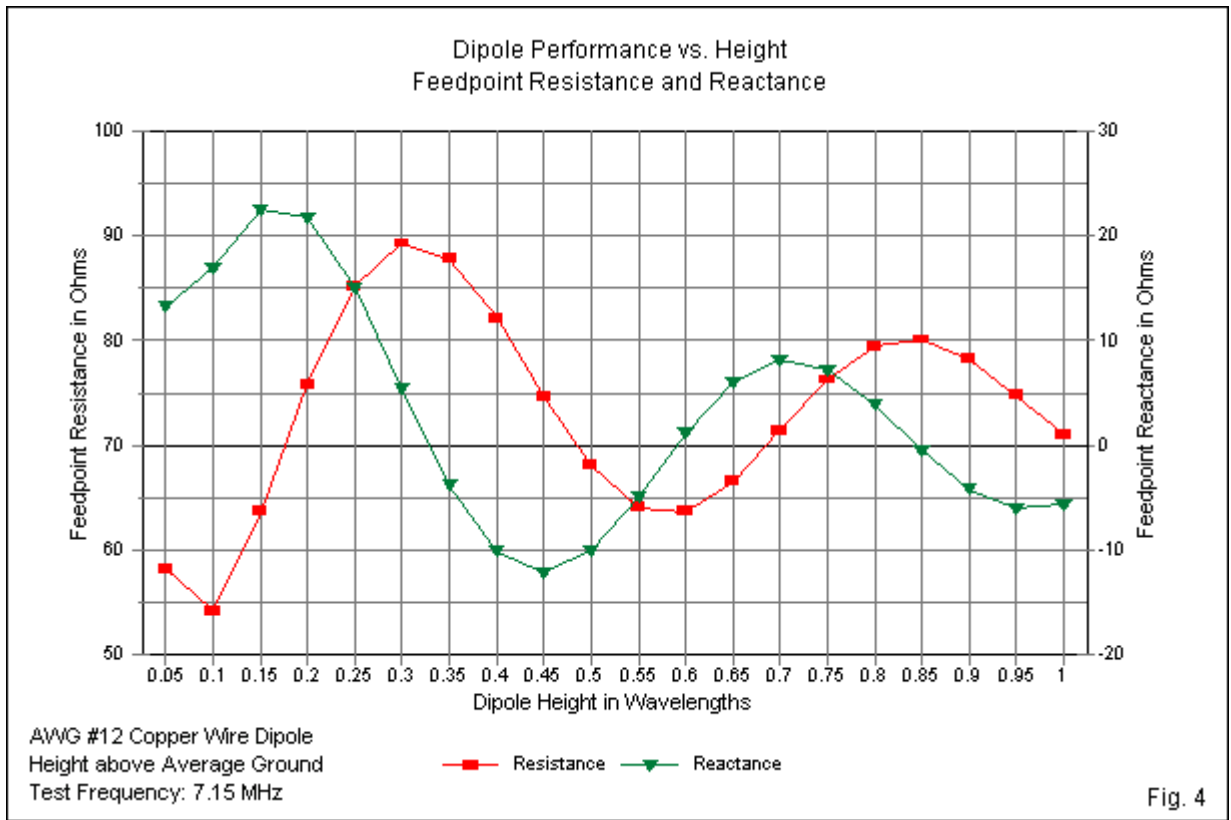

Fig. 4

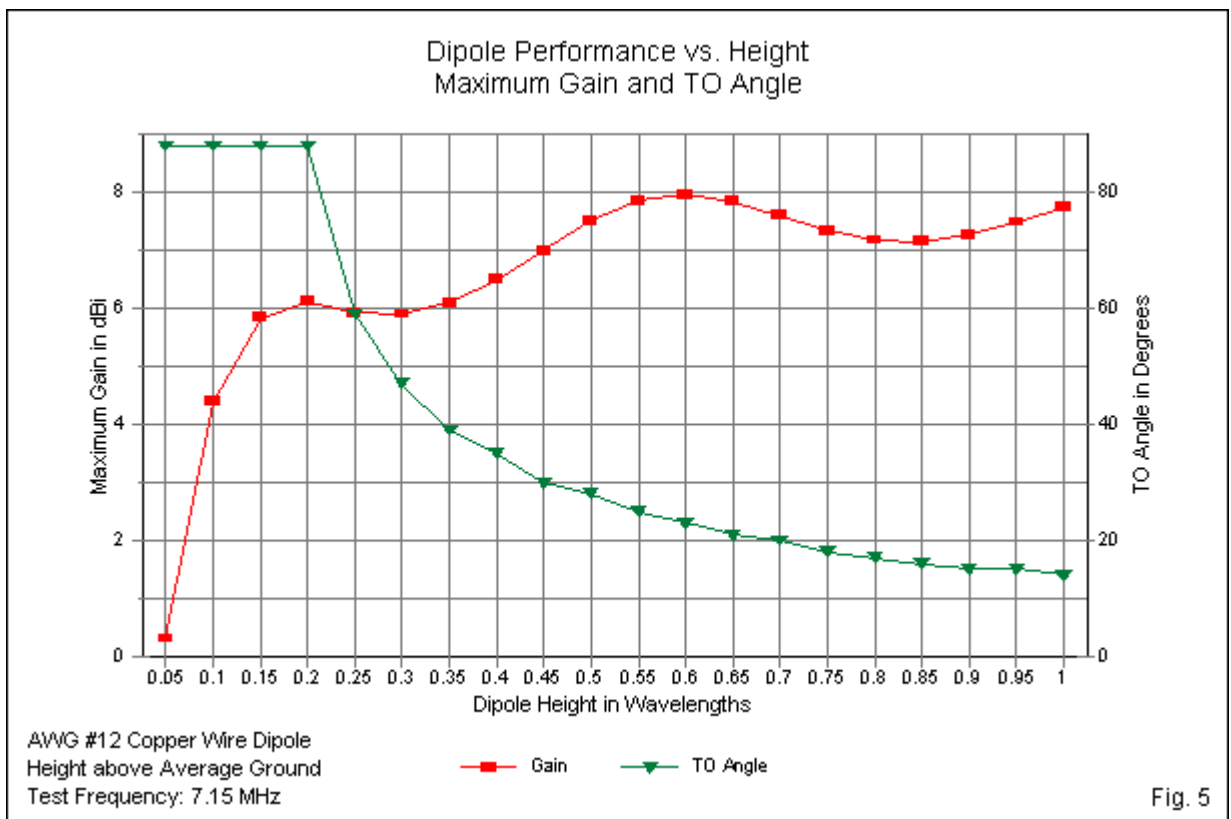

Fig. 5

For a fixed dipole length, the resistive and the reactive components of the impedance at the test frequency will change in a cyclical manner as we change the antenna height above ground. The resistive and the reactive component peaks do not occur at the same heights. Rather, the resistance reaches a peak value at a height where the reactance is close to zero. The curves repeat themselves at approximately half-wavelength intervals in height. As the antenna height increases, the curves flatten out, eventually dwindling to an insignificant variation at a height well above 1λ . We need not trace the curves beyond the table and graph limits since few amateurs install 40-meter dipoles much above $\frac{1}{2} \lambda$.

The TO angle, or the elevation angle of maximum field strength, undergoes a continuous decrease once we elevate that antenna to at least $\frac{1}{4} \lambda$ above ground. The angle for the lowest (sometimes the only) elevation lobe in the pattern decreases ever more slowly as we continue to raise the antenna height. Note that the angle is about 28° when the antenna is 0.5λ high and 14° when the antenna is at 1λ . We might expect an antenna that is 2λ high to show a TO angle of about 7° .

The gain curve is fascinating because it also shows cyclical changes in its value, although at normal heights, we could not notice the changes operationally. We find gain minimums approximately where we also find peak values of the resistive component of the feedpoint impedance. The cycle repeats itself approximately every half wavelength, but like the impedance undulations, the range of values diminishes as we increase the antenna height.

Horizontal antennas of all types do not change their performance properties by a very large amount as we change the quality of ground without altering the antenna height. **Table 3** provides an indication of the amounts of change from very good to very poor ground. Over very good ground, the portion of the radiated energy that reflects from the ground is stronger than over less ground qualities. Ground quality also has a minor but noticeable affect on the TO angle, with better ground qualities producing higher TO angle values.

Table 3. Dipole properties as a function of ground quality: 7.15-MHz AWG #12 copper wire dipole

Ground Quality: Very Good (C = 0.0303 S/m, DC = 20)	Average (C = 0.005 S/m, DC = 13)			Very Poor (C = 0.001 S/m, DC = 5)					
	Gain dBi	TO Deg	Feed Z R+/-jX Ω	Gain dBi	TO Deg	Feed Z R+/-jX Ω	Gain dBi	TO Deg	Feed Z R+/-jX Ω
Height λ									
0.3	6.43	51	94.5 + j8.4	5.90	47	89.3 + j5.4	5.17	43	83.3 + j2.8
0.6	8.60	24	60.6 + j0.9	7.97	23	63.6 + j1.2	7.11	22	67.1 + j1.1
0.9	7.48	16	80.0 - j5.2	7.28	15	71.2 - j5.7	6.94	15	76.3 - j2.9

Note that there seems to be no strict pattern to two factors in the table. The differential between the gain over very good ground and very poor ground does not follow a pattern that tracks height. The differential at 0.6λ is greater than the differential at the other two heights. As well, we find a reversal in the relationship between ground quality and the feedpoint impedance. At 0.3λ and 0.9λ , very good ground shows the highest impedance value, but at 0.6λ , the highest impedance occurs over very poor ground.

Fig. 6 shows both elevation and azimuth patterns for the dipole at each height over each type of ground. Besides showing the relative gain values over each type of ground—with very good ground showing the marginally highest gain values—the patterns also give us samples of the growth of higher-angle elevation lobes as we increase the antenna height above any quality of ground.

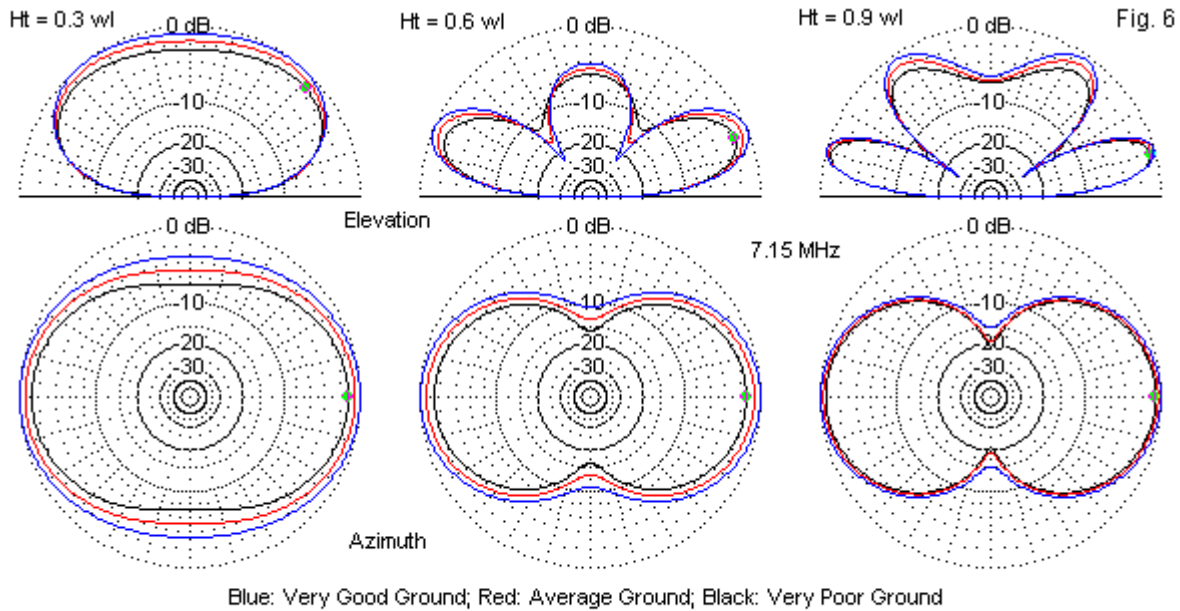

Blue: Very Good Ground; Red: Average Ground; Black: Very Poor Ground
 Sample Elevation and Azimuth Patterns of an AWF #12 Copper Wire Dipole
 at Various Heights above Various Ground Qualities

The azimuth pattern shapes show not only the slightly greater gain of the dipole over very good ground, but also an equally slightly greater gain off the ends of the dipole. In contrast to the deeper azimuth nulls over very poor soil, the elevation patterns show deeper nulls between lobes when the soil is very good. Perhaps more significantly, the high-angle elevation lobes change their relative proportions as we change soil and simultaneously raise the antenna. The pattern for 0.3λ shows essentially two lobes (accounting for the slight reduction in gain at 90° elevation), both at high angles. At 0.9λ , the second lobes have grown very large, encompassing more area than the lower lobes. As well, we can see the considerable difference in high-angle lobe strength as we move from very poor to very good soil. At both levels, the impedance is higher over very good soil than over the lesser ground qualities.

At 0.6λ , some aspects of the patterns reverse. The high angle lobe is just emerging, with not much difference in strength regardless of the soil quality. Over all three soil types, we find that the maximum gain is higher than at 0.9λ , and the gain differential across the three ground quality levels is the greatest. In addition, the impedance is highest for the worst soil rather than for the best. In other words, as we change both the height and the ground quality of an antenna, there are complex cycles of behavior involved.

Before we set aside the current question, we should note the antenna behavior at lower heights, specifically between heights of 0.15λ and 0.25λ . This height range serves near vertical incidence skywave (NVIS) operation. **Fig. 7** shows a special set of elevation patterns. We had noticed that as we reduce the antenna height, the azimuth pattern becomes less of a figure-8 and more of an oval. Hence, at the very high TO angles, we find significant radiation both broadside and endwise to the dipole element. Therefore, for evaluating the NVIS potential for the dipole on 40 meters, we look at both broadside and endwise elevation patterns.

If we use the pattern angular lines—the half-power points—as a guide, then the pattern at 0.15λ (about 21') has the greatest circularity for nearly equal omni-directional coverage. Moving the antenna up to 0.2λ (about 28') yields higher gain, but the broadside pattern now

show two peaks, although the gain depression between peaks is almost invisible. At a height of 0.25λ (about 34'), the broadside pattern has two widely separated peaks, but the widest possible elevation beamwidth. The endwise pattern does not change very much over the NVIS-preferred range.

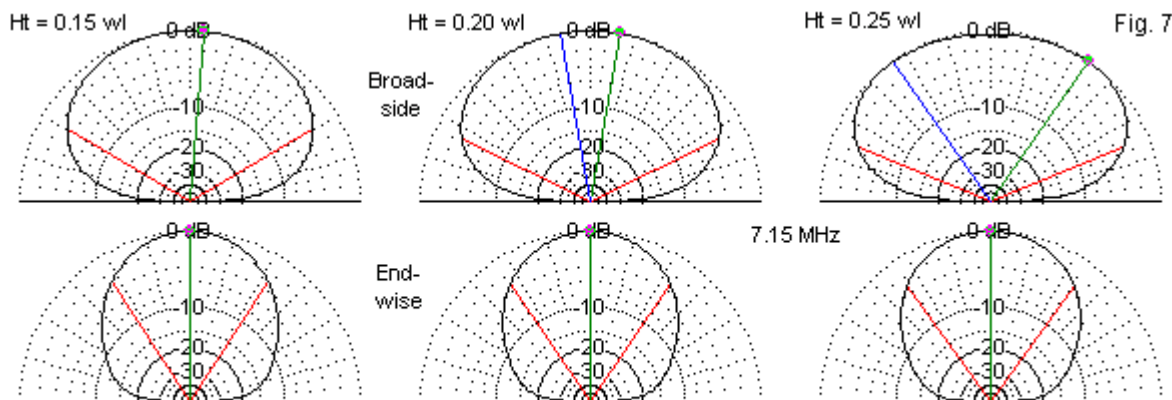

Broadside and Endwise NVIS Patterns for a 40-Meter AWG #12 Copper Wire Dipole at 3 Typical Heights above Average Ground

For minimum-range omni-directional coverage, a height between 0.15λ and 0.2λ is best. However, if the NVIS station also doubles for communication with other station at medium distance, the 0.25λ height may be best, with the 0.2λ height coming in second. NVIS operation represents a special application for full-length dipoles, and the proper height depends on the operational needs of the NVIS station.

For general—usually long-distance—communications, the general rule that applies to the dipole's situation also applies to all horizontal antennas: strive for the greatest height commensurate with antenna durability and periodic maintenance. A practical minimum height is about 0.35λ (about 48'). Although a height between 0.5λ and 0.65λ (69' to 89') is superior, the vertical beamwidth of the low elevation lobe has enough energy at the slightly lower height to allow long-distance communications.

Virtually no amateur 40-meter station places the transceiver at the antenna feedpoint. Therefore, we employ a transmission line to guide energy in both directions between the transceiver and the antenna. Although we can specify a parallel transmission line with a high impedance and use an antenna tuner at the transceiver end of the line, we normally install a coaxial cable. Most amateurs will use a 50- Ω coaxial cable in preference to a 70-75- Ω cable. There is a reason for this practice, even though the impedance values at the antenna feedpoint at most heights above ground tend to favor the higher-impedance cable for the closest match between the antenna and feedline impedance values. Feedlines of any sort have losses, and that fact tends to favor the use of 50- Ω cable. The SWR graph in **Fig. 2** shows that we almost obtain a very usable SWR curve with 50- Ω cable before factoring in the losses, and the losses directly assignable to the SWR will not be significant with a 2:1 value at the band edges.

When we factor in the cable losses, we discover a benefit. Let's assume that we require 100' of coaxial cable to reach between the transceiver and the antenna. **Table 4** provides some data on what we can expect from three types of 50- Ω cables using three sample antenna heights: 0.3λ , 0.6λ , and 0.9λ .

Table 4. Dipole properties with 100' of 50-Ω coaxial cable attached

Antenna Height: 0.3 λ			0.6 λ			0.9 λ			
Cable	Gain	TO	Feed Z	Gain	TO	Feed Z	Gain	TO	Feed Z
Type	dBi	Deg	R+/-jX Ω	dBi	Deg	R+/-jX Ω	dBi	Deg	R+/-jX Ω
None	5.90	47	89.3 + j5.4	7.97	23	63.6 + j1.2	7.28	15	71.2 - j5.7
RG-213	5.34	47	53.9 - j27.5	7.46	23	53.2 - j11.4	6.73	15	49.8 - 20.6
RG-8X	5.00	47	51.9 + j24.2	7.18	23	52.1 + j9.4	6.42	15	56.9 + j18.1
RG-58A	4.62	47	59.7 + 21.7	6.83	23	54.7 + 7.6	6.06	15	62.1 + j14.0

Cable Specification	Zo	VF	Loss/100' @ 10 MHz
RG-213	50	.66	0.6 dB
RG-8X	50	.80	0.9 dB
RG-58A	50	.78	1.3 dB

The table lists values for the hypothetical case of placing the transceiver at the antenna terminals. The three cables are RG-58A, RG8X, and RG-213. RG-58A is among the cheapest, lightest, and most readily available cables around. RG-8X is only slightly heavier, but has considerably lower losses, as indicated by the listings below the table itself. RG-213 is a standard post-World-War-II improved version of RG-8 that uses a solid dielectric. The other cables use a foam dielectric, as indicated by the higher velocity factor (VF) values. The differences in losses per 100' of cable appear in the revised antenna gains in the table. The difference in each case between the listed gain and the “no-cable” gain represents the losses in the cable itself. All values are for 7.15 MHz. Obviously, for the very best results, one should use the cable with the lowest loss, and there are relatively new cables with very low losses indeed, but with a higher price tag. For the antenna builder, the selection of cables is a balance among system efficiency, cost, and weight.

The benefit of using a 50-Ω cable that has some loss is that the losses tend to reduce the SWR (relative to a 50-Ω standard) along the length of the line, moving from the antenna toward the transceiver. **Fig. 8** shows the 50-Ω SWR curves for the no-cable situation and for the situation in which we insert 100' of RG58 when the antenna is 1 λ above average ground. The resulting 50-Ω SWR curve is perfectly satisfactory for most operational needs. (An exception is the use of a high-power amplifier with a sensitive fold-back circuit that cuts off with SWR values higher than 1.5:1. Such amplifiers would require the use of cables with higher power handling capabilities than RG-58A.)

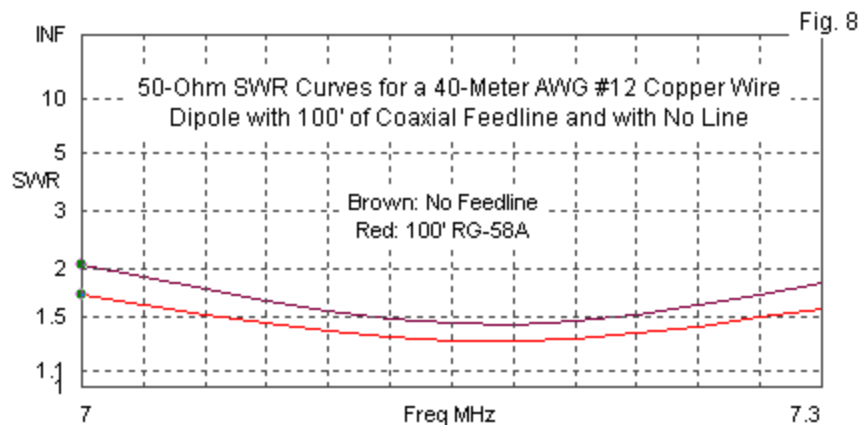

There is a misimpression that, if we replace our full-length dipole with a folded dipole for 40 meters, we shall achieve better performance. As shown in **Fig. 9**, a folded dipole uses two long wires connected at the ends. We feed the antenna at the center of only one of the two long wires. If the two wires of the folded dipole have the same diameter, then the distance (up to a point) is not critical and the antenna shows a 4:1 impedance ratio compared to a comparable single-wire dipole. The impedance, but not the performance, of the folded dipole will change if one wire is fatter than the other one.

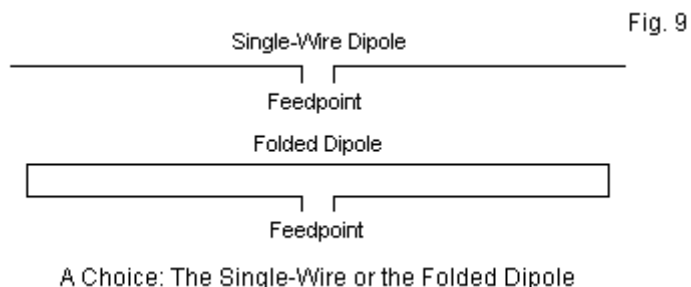

As shown by the data in **Table 5** for both a single-wire and a folded dipole in free space, the gain does not change significantly. Both antennas use AWG #12 copper wire. The folded dipole uses a 2" spacing between long wires. Hypothetically, the folded dipole impedance should be almost 293 Ω . However, let's note a few fine points about the antennas. The two wires of the folded dipole simulate a single wire that is somewhat fatter than the AWG #12 wire in the single-wire version. Fatter wires call for reduced length for resonance. So the folded dipole is noticeably shorter than the single-wire dipole. Shorter antennas generally show lower impedance values, and so the sample folded dipole has a feedpoint impedance slightly under the theoretical 4:1 ratio. Fatter wires—up to a point—show slightly higher gain values, and the folded dipole is no exception.

Table 5. Dimensions and free-space performance of AWG #12 single-wire and folded dipoles

Dipole Type	Length Feet	Length Inches	Feedpoint Z R +/- jX Ω	Max. Gain dBi		
				7.0 MHz	7.15 MHz	7.3 MHz
Single-Wire	66.87	802.4	73.2 - j0.0	2.05	2.07	2.09
Folded Dipole	66.08	793.0	288.7 + j0.0	2.08	2.10	2.12

The comparison between the single-wire and the folded dipoles presents an opportune point to note that for any dipole, the gain values does not change significantly across the 40-meter band. In fact, the range of the gain change is the same for both antennas: 0.04 dB, a value that we can only detect in models but never measure by an instruments accessible to amateur radio stations. In fact the difference in gain between a single-wire dipole and a folded dipole does not even show up in overlaid polar plots for the two antennas. **Fig. 10** presents just such a plot, and the overlapping lines are clearly apparent for their lack of detectable difference.

The figure also presents SWR curves for both types of dipoles. The single-wire dipole uses a 75- Ω reference, while the folded dipole uses a 288- Ω standard. The folded dipole curve is slightly broader, not as a function of the folded configuration, but rather as a function of the simulated fat wire created by the 2" separation. Had we used a fat element for the single wire version, it, too, would show a broader curve. Likewise, altering the spacing between folded dipole wires (and readjusting the length for resonance) would yield slight changes in its SWR

curve. Essentially, the single-wire dipole and the folded dipole are virtually radiation behavior twins.

Comparative Free-Space E-Plane
Patterns and SWR Curves
Referenced to Resonant
Impedance: Single-Wire
Dipole and Folded Dipole

Fig. 10

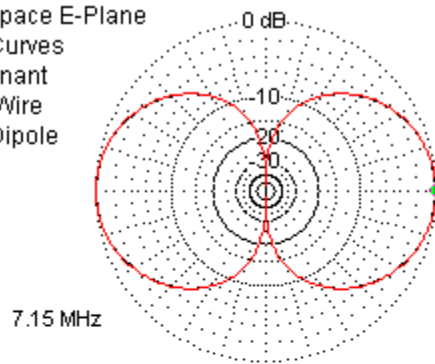

Both dipoles constructed from AWG #12 copper wire. Folded dipole uses a 2" separation of wires.

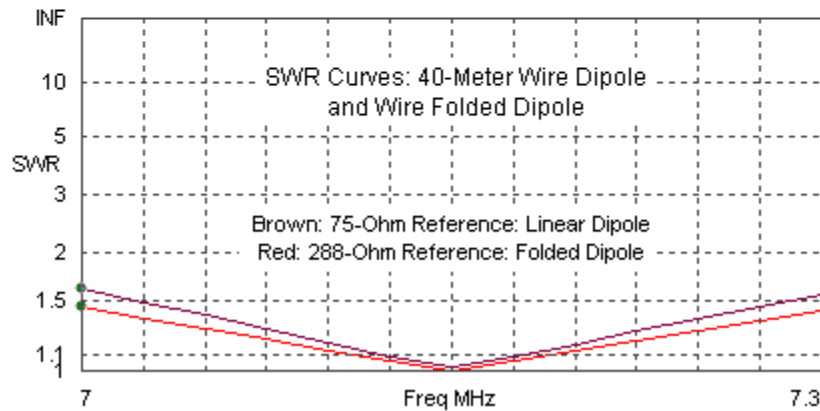

The $\frac{1}{2} \lambda$ dipole holds a special place in amateur radio antenna technology because it forms a building block for other more complex antennas. **Fig. 11** sketches some of the most common forms of antennas that use the dipole as a foundation.

Fig. 11

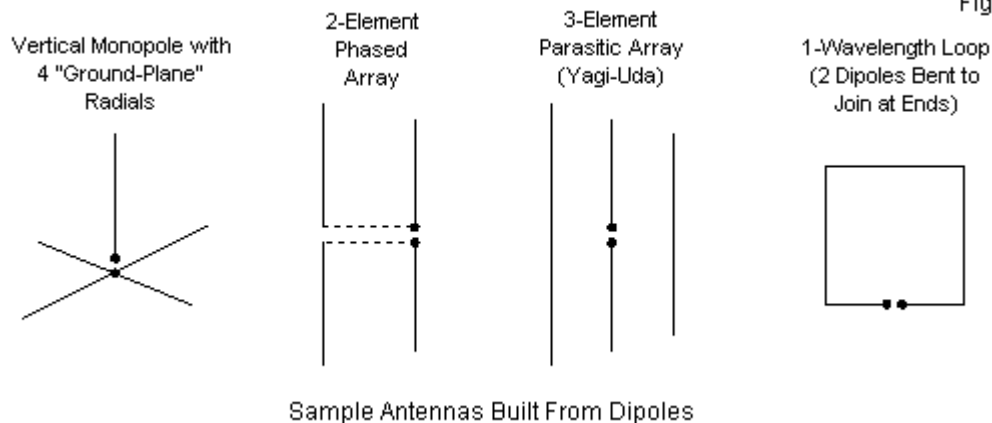

We normally think of a vertical monopole as half a dipole, that is, as a $\frac{1}{4} \lambda$ radiating elements. However, the radials create in a distributed form the other half of the dipole. When we elevate the total antenna, as we do in VHF applications, the length of the radials becomes a

critical dimension in setting the feedpoint to resonance at a desired impedance value. The current on the vertical element reappears on the radials, with a magnitude that is divided by the number of radials. The symmetry of the radials effectively cancels the potential horizontal radiation from these elements. Without the radials, the $\frac{1}{4} \lambda$ vertical element will not operate properly.

The second sketch shows two horizontal dipole elements with a phasing (dashed) line between them. We can use various methods to set the relative current magnitude and phase angles on the two elements in order to achieve various directional patterns to enhance communications. An alternative to the use of phasing lines or networks appears in the third sketch of a 3-dipole element Yagi-Uda (usually shortened to Yagi) beam. Careful selection of element length and spacing values can yield highly directional radiation patterns without the use of connecting lines. Among directional antennas used in amateur radio, parasitic arrays are most common.

The last antenna, a 1λ loop, may seem surprising. Such loops are used independently as bi-directional antennas with gain over a single dipole or with other loops in parasitic arrays called quad beams. A 1λ loop actually consists of two $\frac{1}{2} \lambda$ dipoles with the ends bent to meet each other to create a continuous wire. The dipole current distribution repeats itself on both the upper and lower halves of the loop, even though we use only a single feedpoint.

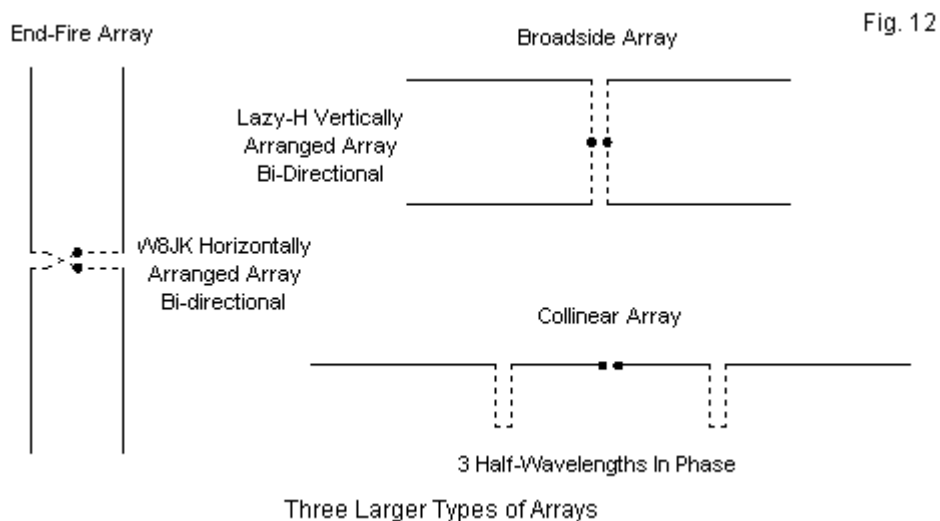

In **Fig. 12**, we see even larger arrays, with a sample from each of the three main array categories: end-fire, broadside, and collinear. The W8JK array places two horizontal elements in a line with each phased 180° opposite to the other. The result is a bi-directional pattern in line with the two elements with increased gain over a simple dipole. The Lazy-H array arranges its wires in a vertical plane, although the main pattern is bi-directional and broadside to the plane formed by the wires. We feed the elements in phase to achieve considerable gain over a single dipole.

The last sketch shows three $\frac{1}{2} \lambda$ element stretched end to end, that is, collinearly. Between each element, we place a phase reversing network or line that sets all three elements in phase with each other. The result is increased bi-directional gain relative to the $\frac{1}{2} \lambda$ building block out of which we created the array. We can string together any number of element sections and use

a wide variety of phase-setting techniques in order to end up with very high gain in a very narrow beam.

Although most of these arrays are incidental to our main project of exploring shortened dipoles, they are fundamental aspects of our understanding and appreciation of the basic $\frac{1}{2} \lambda$ dipole.

Conclusion and Preface

We have examined the full-size $\frac{1}{2} \lambda$ center-fed resonant dipole in some (but not exhaustive) detail to set the stage for what comes next as we prepare to tackle half-length dipoles. The tables, graphs, and patterns shown in these initial notes will form a background against which the shorter dipoles and the techniques of making them work will take center stage. The data that we have surveyed gives us clues as to what properties may be important to consider and what adjustments we may have to make in order to create a working short dipole. In addition, the data values give us a baseline against which to measure the half-length dipoles. The numerical comparisons may require some interpretation along the way, but at least we have some basic values to use as touchstones.