

The Inverted-U

L. B. Cebik, W4RNL

The ARRL Field Day and other operations in the field tend to lean on three antenna principles—simplicity, small size and light weight. Complex assemblies increase the number of things that can go wrong. Large antennas are hard to transport and sometimes do not fit the space available. Heavy antennas require heavy support structures, so the overall weight seems to increase exponentially with every added pound of antenna.

In recent years, a number of light collapsible masts have hit the scene. When properly guyed with ropes, some will support antennas in the 5 to 10 pound range. Most are suitable for 10 meter tubular dipoles and as supports for wire antennas. The masts also allow the user to hand-rotate some antennas so that they are broadside to the desired target station. If we could only extend the range of the antenna to cover 20 through 10 meters, we might put these 20 to 30 foot masts to even better use. The inverted-U is an old idea that may provide one answer.

The Basic Idea

A dipole's highest current occurs within the first half of the distance from the feed point to the outer tips. We lose very little performance if we fold, bend or mutilate the outer end sections to fit an available space. If we start with a tubular 10 meter dipole—a little over 200 inches in overall length—we might add extensions for 12, 15, 17

A simple rotatable field dipole for 20 through 10 meters.

or 20 meters, shaping them to suit the area in which we are operating.

If we can find space to erect a 10 meter rotatable dipole at least 20 feet above the ground, with a clear area to permit us to rotate the dipole, then we can simply let the extensions hang down. Figure 1 shows the relative proportions of the antenna on all bands from 10 to 20 meters. The 20 meter extensions are the length of half the 10 meter dipole. Safety dictates an antenna height of at least 20 feet to keep the tips above the 10 foot level. At any power level,

the ends of a dipole are at a high RF voltage while transmitting and we must keep them out of contact with human body parts.

In principle, we do not lose very much signal strength by drooping up to half the overall element length straight down. What we lose in bidirectional gain shows up in decreased side-nulls as we increase the length of the drooping section. Figure 2 shows the free-space E-plane (azimuth) patterns of the inverted-U with a 10 meter horizontal section. There is an undetectable decrease in gain between the 10 meter and 15 meter versions. The 20 meter version shows a little over a half dB broadside gain decrease and a signal increase off the antenna ends. On 15 meters, the current in the vertical wires becomes significant, rounding the pattern.

The real limitation of an inverted-U is a function of the height of the antenna above ground. With the feed point at 20 feet above ground, we obtain the elevation patterns shown in Figure 3. The 10 meter pattern is typical for a dipole that is about $\frac{3}{8}\lambda$ above ground. On 15 meters, the antenna is only 0.45λ high, with a

resulting increase in the overall elevation angle of the signal and a reduction in gain. At 20 meters, the angle grows still higher, and the signal strength diminishes as the antenna height drops to under 0.3λ . Nevertheless, the signal is certainly usable. A full-size dipole at 20 meters would show only a little more gain at the same height, and the elevation angle would be similar to that of the inverted-U,

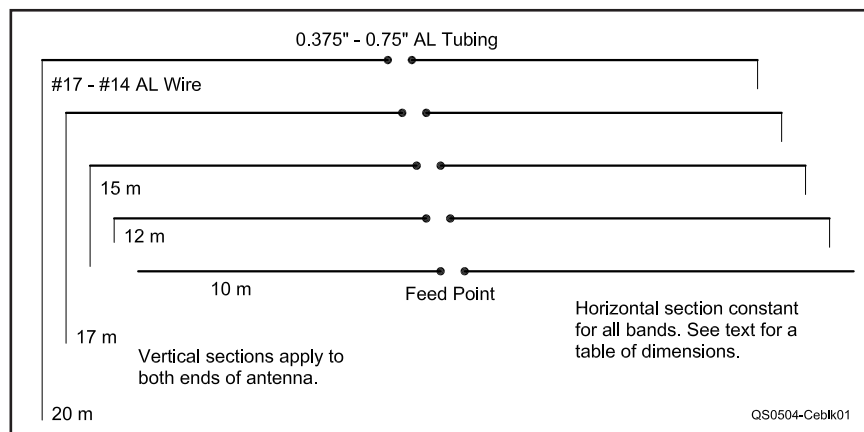

Figure 1—The general outline of the inverted-U field dipole for 20 through 10 meters. Note that the vertical end extension wires apply to both ends of the main 10 meter dipole.

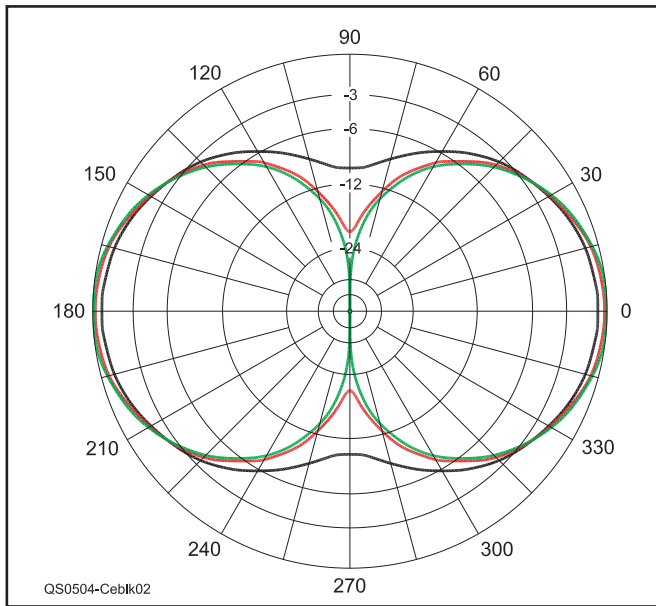

Figure 2—Free-space E-plane (azimuth) patterns of the inverted-U for 10 (green), 15 (red) and 20 (black) meters, showing the pattern changes with increasingly longer vertical end sections.

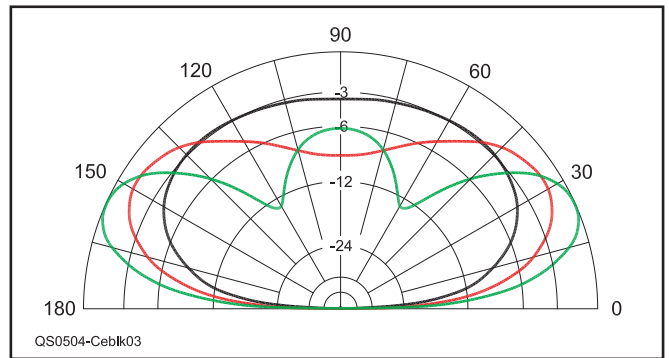

Figure 3—Elevation patterns of the inverted-U for 10 (green), 15 (red) and 20 (black) meters, with the antenna feed point 20 feet above average ground. Much of the decreased gain and higher elevation angle of the pattern at the lowest frequencies is due to its lower height as a fraction of a wavelength.

despite the difference in antenna shape.

As we decrease our frequency, there is no substitute for antenna height. Any horizontal antenna below about $\frac{3}{8} \lambda$ in height will show a rapid decrease in low angle performance relative to heights above that level. If we raise the inverted-U to 40 feet, the 20 meter performance would be very similar to that shown by the 10 meter elevation plot in Figure 3. Table 1 summarizes the free-space and 20 foot performance characteristics of the inverted-U. Of special note is the fact that the feed-point impedance of the inverted-U remains well within acceptable limits for virtually all equipment, even at a height as low as 20 feet above ground. The SWR curves are also acceptably broad. Finding exact dimensions, even in special field conditions, becomes a non-critical task.

If we can accept the performance potential of a dipole for any band in the 20 meter to 10 meter range at the anticipated height of our most possibilities, then the inverted-U provides a compact way of achieving that performance. The next step is fabricating

one that we can use in the field.

Building a Field Version of the Inverted-U

Let's approach the construction of a field inverted-U in three steps: First, the tubing arrangement, second the center hub and feed-point assembly and third the drooping extensions. A parts list appears in Table 2.

1. *The aluminum tubing dipole for 10 meters.* Each half of the aluminum tubing dipole consists of three longer detachable sections of tubing and a short section mounted permanently to the feed-point plate, as shown in Figure 4. Let's consider each half of the element separately. Counting from the center of the plate—the feed point—the element extends 5 inches using $\frac{3}{4}$ inch aluminum tubing. Then we have two 33 inch exposed tubing sections, with an additional 3 inches of tubing overlap per section. These sections are $\frac{5}{8}$ and $\frac{1}{2}$ inch in diameter, respectively. The exposed outer section is 30 inches long (with at least a

3 inch overlap) and consists of $\frac{3}{8}$ inch diameter tubing.

Since the $\frac{5}{8}$ and $\frac{1}{2}$ inch sections are 36 inches long, you can make the outer $\frac{3}{8}$ inch section the same overall length and use more overlap, or you can cut the tubing to 33 inches and use the 3 inch overlap. That much overlap is sufficient to ensure a strong junction while minimizing excess weight. When not in use, the three outer tubing sections will nest inside each other for storage. A 36 inch length for the outer section is a bit more convenient to un-nest for assembly. (I keep the end hitch pin on the $\frac{3}{8}$ inch tubing as an easy way of pulling it into final position.) I prefer to use the readily available 6063-T832 aluminum tubing that nests well and has a long history of antenna service.

The only construction operation that you need to perform on the tubing is to drill a hole at about the center of each junction to pass a hitch pin clip. Obtain hitch pin clips (also called hairpin cotter pin clips in some literature) that fit snugly over the tubing.

Table 1

Anticipated Performance of the Inverted-U for 20 through 10 Meters

Using the tubular 10 meter dipole described in the text and #17 to #14 vertical wire element extensions.

Band	Gain (dBi)	Free-Space		20' Above Average Ground		
		Resonant Impedance (Ohms)	Wire Length (inches) #17	Gain (dBi)	Elevation Angle (deg)	Impedance $R \pm jX$ (Ohms)
10	2.1	73	—	7.6	24	$65 - j2$
12	2.0	71	16	7.2	27	$67 - j8$
15	1.9	64	38	6.4	32	$69 - j8$
17	1.7	55	62	5.7	38	$65 - j4$
20	1.4	41	108	4.8	50	$52 + j4$

Note: The wire length for the drooping ends is measured from the end of the 202 inch tubular dipole to the tip for #17 wire. Little change in length occurs as a function of a change in wire size. However, attachment of the extension to the element and special field conditions may require a few extra inches of wire.

**Table 2
Parts List**

Substitutions and alternative construction methods are possible and encouraged—as long as the overall antenna weight is not increased.

Qty	Part	Comments
6'	0.375" OD aluminum tubing	Two - 3' pieces
6'	0.5" OD aluminum tubing	Two - 3' pieces
6'	0.625" OD aluminum tubing	Two - 3' pieces
10"	0.75" OD aluminum tubing	Two - 5" pieces
4"	0.5" nominal (5/8" OD) CPVC	
50'	#17 wire	See Table 1 for the length of each piece. Aluminum preferred, but copper usable.
8	Hitch pin clips	Sized to fit tubing junctions.
1	4"x4"x1/4" Lexan plate	Other materials suitable.
2	SS U-bolts	Sized to fit support mast.
2	Sets SS #8/10 1.5" bolt, nut, washers	SS = stainless steel.
2	Sets SS #8 1" bolt, nut, washers	
2	Sets SS #8 0.5" bolt, nut, washers	
1	Coax connector bracket, 1/16" aluminum	See text for dimensions and shape.
1	Female coax connector	
2	Solder lugs, #8 holes	
2	Short pieces copper wire	From coax connector to solder lugs.

Note: 6063-T832 aluminum tubing is preferred and can be obtained from Texas Towers, www.texastowers.com, and other outlets. Lexan (polycarbonate) is available from McMasters-Carr, www.mcmasters.com, as are the hitch pin clips (if not locally available). Other items should be available from local home centers and radio parts stores.

tuned element, tape the outer section in position and test the dipole on your mast at the height that you will use in the field. Adjust the length of the outer tubing segments equally at both ends for the best SWR curve on the lower 1 MHz of 10 meters. Even though the impedance will be above 50 Ω throughout the band, you should easily obtain an SWR curve under 2:1 that covers the entire band segment. However, you cannot perform this test until you construct a feed point and mounting plate.

2. *The center hub: mounting and feed-point assembly.* I constructed the plate for mounting the element and the mast from a 4x4x1/4 inch thick scrap of polycarbonate (trade name Lexan), as shown in Figure 5. You may use other materials as long as they will handle the element weight and stand up to field conditions.

At the top and bottom of the plate are holes for the U-bolts that fit around my mast. Since field masts may vary in diameter at the top, size your U-bolts and their holes to suit the mast.

The element center, consisting of two 5 inch lengths of 3/4 inch aluminum tubing, is just above the centerline of the plate (to allow room for the coax fitting below). CPVC tubing of 1/2 inch nominal size has an outside diameter of about 3/8 inches and makes a snug fit inside the 3/4 inch tubing. The CPVC aligns the two aluminum tubes in a straight line and allows for a small (about 1/2 inch) gap between them. When centered between the two tubes, the CPVC is the same width as the plate. A pair of 1 1/2 inch #8 or #10 stainless steel bolts—each bolt with washers and a nut—secures the element to the plate.

Note in the sketch that you may insert the 5/8 inch tube as far into the 3/4 inch tube as it will go and be assured of a 3 inch overlap. I drilled all hitch pin clip holes perpendicular to the plate. Although this alignment is not critical to the junctions of the tubes, it is important to the outer ends of the tubes when we use the antenna below 10 meters.

I mounted a single-hole female UHF connector on a bracket made from a scrap of 1/16 inch thick L-stock that is 1 inch on a side. I drilled the UHF mounting hole first, before cutting the L-stock to length and trimming part of the mounting side. Then I drilled 2 holes for 1/2 inch long #8 stainless steel bolts about 1 inch apart, for a total length of L-stock of about 1 1/2 inches. The reason for the wide strip is to place the bolt heads for the bracket outside the area where the mast will meet the plate on the back side. Note in Figure 5 that the bracket nuts are on the bracket-side of the main plate, with the heads facing the mast. The bracket-to-plate mounting edge of the bracket needs to be

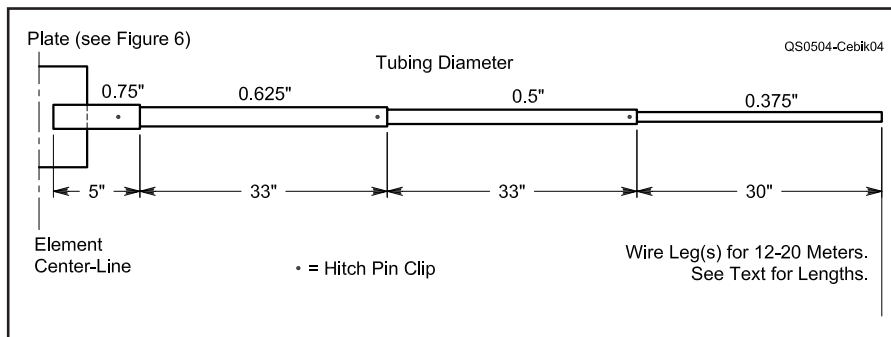

Figure 4—The general tubing layout for the inverted-U for each half element. The opposite side of the dipole is a mirror image of the one shown.

One size will generally handle about two or three tubing sizes. In this antenna, I used 3/32 inch (pin diameter) by 2 5/8 inch long clips for the 3/4 to 5/8 inch and the 5/8 to 1/2 inch junctions, with 3/32 by 1 5/8 inch pins for the 1/2 to 3/8 inch junction and for the final hitch pin clip at the outer end of the horizontal part of the antenna. Drill the holes (1/8 inch diameter) for the clips with the adjacent tubes in position relative to each other. I generally tape the junction temporarily for the drilling. Carefully deburr the holes so that the tubing slides easily when nested.

For this field antenna, the hitch pin clip junctions, shown in Figure 5, hold the element sections in position. The overlapping portions of the tube make the actual electrical contact between sections. Due to the effects of weather, junctions of this type are not suitable for a permanent installa-

tion, but are completely satisfactory for short-term field use. Good electrical contact requires clean, dry aluminum surfaces, so do not use any type of lubricant to assist the nesting and un-nesting of the tubes. Instead, clean both the inner and outer surfaces of the tubes before and after each field use.

Hitch pin clips are fairly large and harder to lose in the grass of a field site than most nuts and bolts. However, you may wish to attach a short colorful ribbon to the loop end of each clip. Spotting the ribbon on the ground is simpler than probing for the clip alone.

Each element half is 101 inches long, for a total 10 meter dipole element length of 202 inches. Length is not critical within about ±1 inch, so you may pre-assemble the dipole using the listed dimensions. However, if you wish a more precisely

only about $\frac{3}{4}$ inch wide, so you may trim that side of the L-stock accordingly.

With the element center sections and the bracket in place, I drilled two holes for 1 inch long #8 stainless steel bolts at right angles to the mounting bolts and as close as feasible to the edges of the tubing at the gap. These bolts have solder lugs attached for short leads to the coax fitting. Solder lugs do not come in stainless steel, so you should check these junctions before and after each use for any corrosion that may call for periodic replacement.

With all hardware in place, the hub unit is about 4x10x1 inches (plus U-bolts). It will remain a single unit from this point onward, so that your only field assembly requirements will be to extend tubing sections and install hitch pin clips. You are now ready to perform the initial 10 meter resonance tests on your field mast.

3. *The drooping extensions for 12 through 20 meters.* The drooping end sections consist of aluminum wire. Copper is usable, but aluminum is lighter and quite satisfactory for this application. Table 1 lists the approximate lengths of each extension below the element. Add 3 to 5 inches of wire—less for 12 meters, more for 20 meters—to each length listed.

Initially, I had hoped to use #14 aluminum wire. However, this material is becoming harder to find locally. A good substitute is common #17 aluminum electric fencing wire. Fence wire is stiffer than most wires of similar diameter, and it is cheap. Stiffness is the more important property, since we do not want the lower ends of the wire to wave excessively in the breeze, potentially changing the feed-point properties of the antenna while in use.

When stored, the lengths of wire extensions for 12 and 15 meters can be laid out without any bends. However, the longer extensions for 17 and 20 meters will require some coiling or folding to fit the same space as the tubing when nested. Fold or coil the wire around any kind of small spindle that has at least a 2 inch diameter. This measure prevents the wire from crimping and eventually breaking. Murphy dictates that a wire will break in the middle of an operating session. So carry some spare wire for replacement ends. The low cost of fencing wire (about \$5 for 250 feet in my area) allows me to tote the entire spool with me to operating sites. All together, the ends require about 50 feet of wire.

Figure 6 shows the simple mounting scheme for the end wires. I push the straight wires through a pair of holes aligned vertically to the earth. I then bend the top portion slightly. To clamp the wire, I insert a hitch pin clip through holes parallel to the ground, pushing the wire slightly to one

side to reach the far hole in the tube. The double bend holds the wire securely (for a short-term field operation), but allows the wire to be pulled out when the session is over or when I change bands.

Add a few inches to the lengths in Table 1 as an initial length for each band. Test the lengths and prune the wires until you obtain a smooth SWR curve below 2:1 at the ends of each band. Since an inverted-U antenna is full length, the SWR curves will be rather broad and suffer none of the narrow bandwidths associated with inductively loaded elements. Figure 7 shows modeled SWR curves for each band to guide your expectations. Unless your feed line is an exact multiple of a half-wavelength, the impedance that you might record on any of the antenna analyzer instruments may differ from the impedance at the feed point.

The impedance figures for a 20 foot height shown in Table 1 suggest that you should not require much, if any, adjustment once you have found satisfactory lengths for each band. However, leave enough excess so that you can adjust the lengths in the field, especially if you operate in an area where objects like trees and buildings are at different distances from the antenna than they are in your test setup. My initial tests required extension wires considerably longer than modeled, with the peak excess on 15 meters. Only during a second round of tests did I realize that my test mast is metal, ungrounded, and just about 22 feet long. The need for longer extensions likely resulted from coupling between the extensions and the mast, although nothing seemed amiss in reception tests. The pattern was clearly bi-directional.

Do not be too finicky with your SWR

curves in the field. An initial test and possibly one adjustment should be all that you need to arrive at an SWR value that is satisfactory for your equipment. Spending half of your operating time adjusting the elements for as near to a 1:1 SWR curve as may be possible will rob you of valuable contacts without changing your signal strength in any manner that is detectable at the far end of the line.

Changing bands is now a simple matter. Remove the ends for the band you are using and install the ends for the new band. An SWR check and possibly one more adjustment of the end lengths will put you back on the air.

Some Final Notes

The inverted-U dipole with interchangeable end pieces provides a compact field antenna. Figure 8 shows the parts in their travel form, illustrating how compactly the antenna travels. When assembled and mounted at least 20 feet up (and higher is still better), the antenna will compete with just about any other dipole mounted at the same height. But the inverted-U is lighter than most dipoles at frequencies lower than 10 meters. It also rotates easily by hand—assuming that you can rotate the mast by hand. Being able to broadside the dipole to your target station gives the inverted-U a strong advantage over a fixed wire dipole.

You may experiment with other forms of construction according to your own skills and available materials. A wire version can be taped to bamboo poles, if you can obtain the material and find a means of connecting short transportable sections of bamboo. Try to avoid aluminum conduit and other heavy materials. Be certain

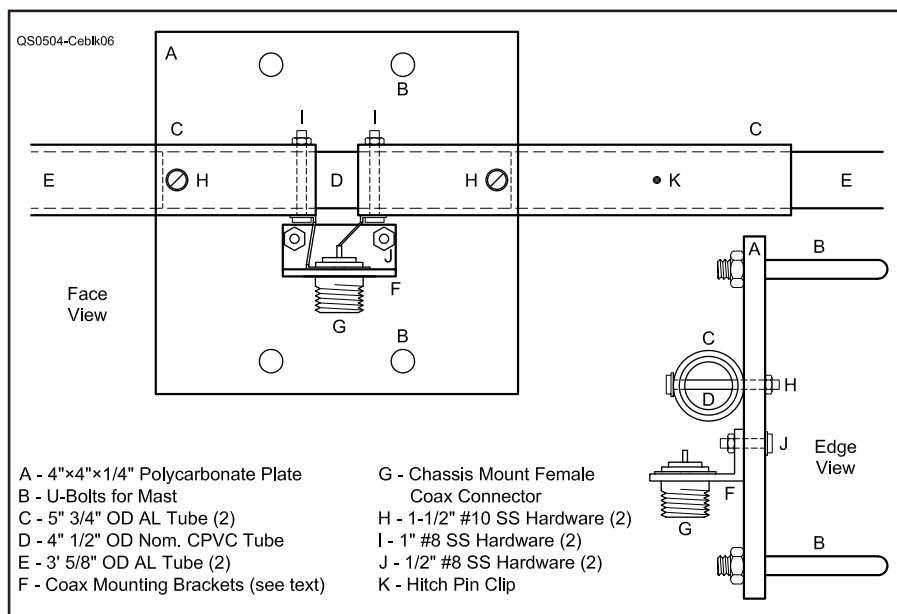

Figure 5—The element and feed-point mounting plate, with details of the construction used in the prototype.

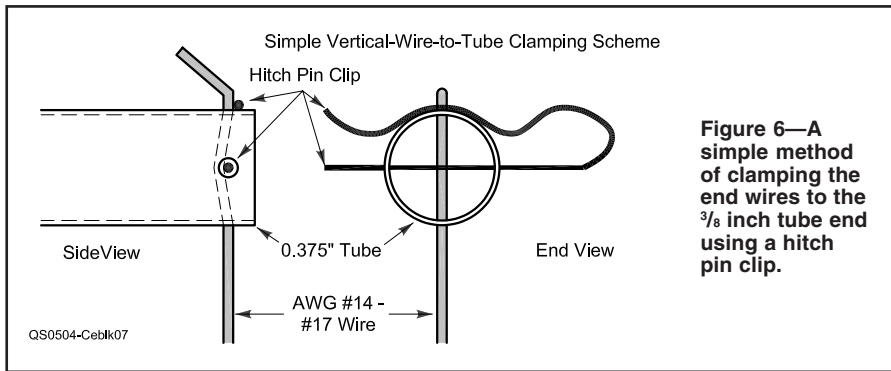

Figure 6—A simple method of clamping the end wires to the 3/8 inch tube end using a hitch pin clip.

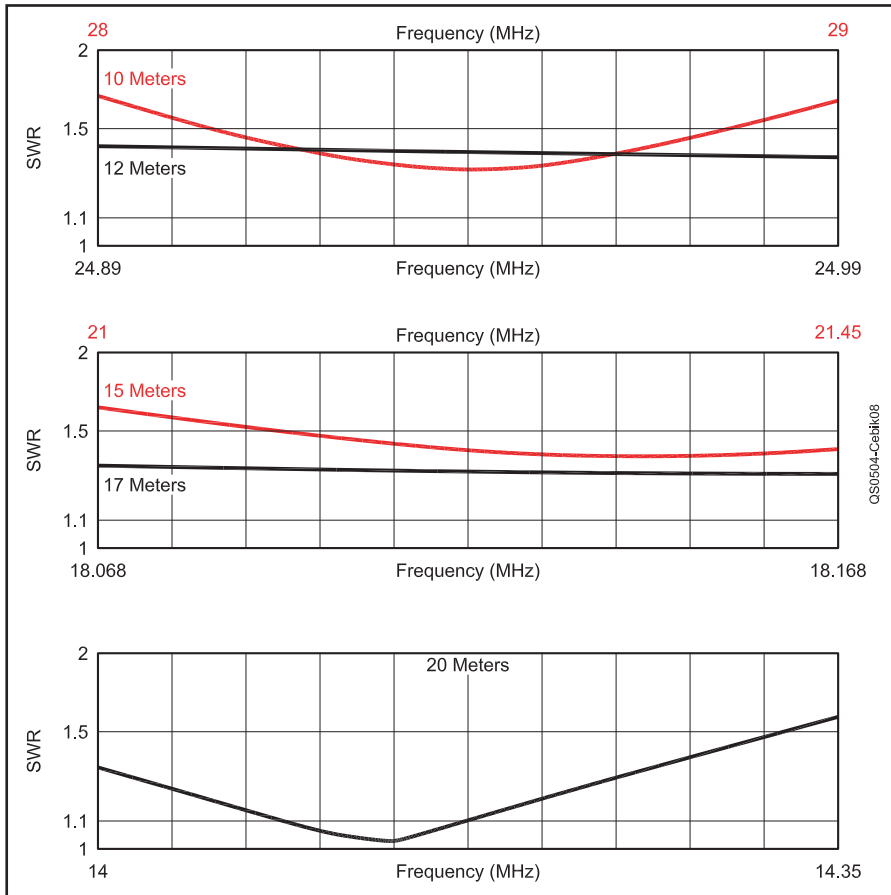

Figure 7—Typical 50 Ω SWR curves for the inverted-U antenna at a feed-point height of 20 feet.



Figure 8—The entire inverted-U antenna parts collection in semi-nested form, with its carrying bag and the three dedicated tools for field assembly and disassembly.

that the drooping end wires are well secured to the 10 meter dipole ends both electrically and mechanically.

With a dipole having drooping ends, safety is very important. Do not use the antenna unless the wire ends for 20 meters are higher than any person can touch when the antenna is in use. Even with QRP power levels, the RF voltage on the wire ends can be dangerous. With the antenna at 20 feet at its center, the ends should be at least 10 feet above ground. For this reason, I have not tried to extend the inverted-U for use on 30 and 40 meters.

Equally important is the maintenance that you give the antenna before and after each use. Be sure that the aluminum tubing is clean—both inside and out—when you nest and unnest the sections. Grit can freeze the sections together, and dirty tubing can prevent good electrical continuity when the antenna is extended. Add a few extra hitch pin clips to the package to be sure you have spares in case you lose one.

You can carry all of the parts in any 3 foot long bag, either horizontal or vertical. A draw-string bag works very well. One of the photos shows the antenna pieces and their bag, along with the ribbon spools on which I store the wire extensions, the spool of extra wire, and the *field tools*. The tools that I store with the antenna include a wrench to tighten the U-bolts for the mast-to-plate mount and a pair of pliers to help me remove end wires from the tubing without cutting my fingers. The pliers have a wire-cutting feature in case I need to replace a broken end wire. A pair of Vise-Grip pliers makes a good removable handle for turning the mast. The combination of the Vise-Grip and regular pliers lets me uncoil the wire extensions for any band and give them a couple of sharp tugs to relax and straighten the wire.

Although the inverted-U is not the answer to every field antenna need, it will serve very well if it matches the kind of operating you do. Hitch pin clips simplify assembly and band changing in the field. At 20 feet and higher, the antenna will acquit itself very well. The entire antenna is inexpensive to build and easy to maintain. Those are reasonably good credentials for any antenna.

Licensed since 1954, L. B. Cebik, W4RNL, is a prolific writer on the subject of antennas. Since retiring from teaching at the University of Tennessee, LB has hosted a Web site (www.cebik.com) discussing antennas—both theoretical and practical. He has written more than 15 books, including the ARRL course on antenna modeling. Serving both as a Technical and an Educational ARRL Advisor, he's also been inducted into both the QRP and QCWA Halls of Fame. LB can be reached at 1434 High Mesa Dr, Knoxville, TN 38938 or at cebik@cebik.com. 